

SECTION 2

CAMPING EQUIPMENT

(Product Group - 300)

Camping Accessories	058 - 061
Coast Outdoor Gazebo	062
Beaver Cookware	063
Collapsible Homeware	064
RV Kitchenware	064 - 065
Palm Drinkware and Kitchen Accessories	065 - 068



CAR ACCESSORIES

(Product Group - 350)

Towing Accessories	069 - 072
Towing Mirrors	073 - 075
Brake Controllers	076 - 078
Tyre Pressure Monitoring	079
Carry Bikes and Accessories	080 - 085
Hayman Reese Hitches	086 - 087
Eaz Lift WDH and Accessories	088 - 091
Tips For Safer Towing	092 - 093
RV Coaster	094
Throttle Controllers	095



TOW BALLS & ACCESSORIES

350-00018 ARK TOW BALL MOUNT & TOW BALL

The adjustable Ark Tow Ball Mount is designed to level your trailer and vehicle. It has five adjustable points and is suitable for 4x4s.

Max Towing Capacity: 2500kg*

** The towing capacity of the Ark Tow Ball Mount may exceed the towing capacity of the tow bar or vehicle. Always refer to the manufacturers specifications regarding the towing capacity of your tow bar or vehicle.*



350-00021 ARK BLACK SHIN PROTECTOR WITH TOW BALL COVER

Ensures that the tow ball cover is secured whilst towing, suitable for 50mm and 1 7/8" tow balls.



350-00022 3.5 TON, 50MM CHROME PLATED TOW BALL

Shank Size: 22.23mm
Diameter x 51mm,
Towing Capacity 3500kg



350-00024 3.5 TON, 50MM CHROME PLATED TOW BALL

Shank Size: 22.23mm
Diameter x 62mm,
Towing Capacity 3500kg



350-00026 2.5 TON, 50MM CHROME PLATED TOW BALL

Shank Size: 22.23mm
Diameter x 80mm,
Towing Capacity 2500kg



350-00028 2.0 TON, 25.4MM HI RISE 50MM CHROME PLATED TOW BALL

Shank Size: 22.23mm
Diameter x 51mm,
Towing Capacity 2000kg



REESE TOW VEHICLE ACCESSORIES

350-00040 RATCHETING CARGO BAR

Strong and easy to use, the Reese® Ratcheting Cargo Bar will keep your cargo secured in the ute tub, tray or boot. Fitted with rubber end pads it will also protect the vehicle from scratches and metal contact.

The Ratcheting Cargo Bar extends from 102cm to 178cm, fitting most tub and cab chassis utes even fitting SUV or family wagon boots to keep the shopping and luggage where you need it most.

- > Helps prevent cargo from moving during travel
- > Universal fit extends from 102cm to 178cm
- > Padded ratcheting handle making comfortable tightening a breeze
- > Easy ratchet function to tighten means that installation is quick and easy
- > Rubber ends ensure that the vehicle is protected from scratches and cargo slippage



350-00042 SMALL TAILGATE PROTECTIVE PAD

- > Simple installation and removal
- > Secures to tailgate with two attached straps with buckles
- > Top buckle strap secures cargo down to tailgate during transit
- > 600D weather resistant heavy duty fabric with a heavy duty foam core
- > Pad measurement 45cm x 22cm



350-00044 LARGE TAILGATE PAD

- > Universal - fits most medium and larger size tailgates
- > Pad measurement 135cm x 70cm
- > Added cushioning and protection
- > Rainproof tarpaulin material
- > Three straps wrap around tailgate and secure with three buckles
- > Additional hook and loop straps secure cargo to the pad
- > Flap in centre of pad allows tailgate handle access
- > 600D weather resistant heavy duty fabric with a heavy duty foam core



350-00046 TARP CLIPS 4 PC JAR

Need to anchor your tarp, awning or tent but don't have any usable eyelets?

Reese® Tarp Clips are the answer, made with high impact resistant plastic; the Tarp Clips provide hook anchor points to replace torn eyelets or to add additional anchor points where needed. They are ideal for securing canopies, tarps, awnings, tents, covers and much more.



The vice-like gripping power keeps your tarp in place to keep your gear safe and secure from the elements. Sold in a handy-to-store container, the Tarp Clips are ready when you are.

- > Made of high impact resistant material that will not damage tarps or canopies
- > Ideal for securing tarps, canopies, awnings, tents, covers and much more
- > Heavy Duty and crack resistant
- > Vice-like gripping power
- > Easy to tighten, easy to release
- > Comes in a handy reusable container for storage; you'll never have to hunt around for them in your toolbox or bag again

350-00048 HITCH PIN LOCK & 3.6M CABLE

Prevent theft and lock your equipment, perfect for ute trays, trailers, caravans, roof and bike racks. Lock your cargo with ease



- > Installs in seconds with a push to lock feature
- > Stays on while towing
- > Braided steel for strength and flexibility
- > 3.6m vinyl coated 10mm cable
- > Corrosion resistant

350-00050 CHROME CLIP-ON TOW BALL COVER

Protect your clothing from grease, clips on securely thanks to the spring clip inside, suits 50mm & 47.63mm (1 7/8") tow balls.



350-00052 BLACK SOFT PVC TOW BALL COVER

Protect your clothing from grease, fits securely thanks to the moulded shape, suits 50mm & 47.63mm (1 7/8") tow balls.



350-00054 BLACK CLIP-ON TOW BALL COVER

Fits securely thanks to the spring inside, suits 50mm & 47.63mm (1 7/8") tow balls.



350-00056 TOW BALL BUDDY COVER & SHIN PROTECTOR

Enhance the look of your tow bar and keep your shins out of trouble with the ark tow ball buddy.



- > Clip on chrome cover
- > Covers ball and ball mount
- > Soft shin protector
- > Suits 50mm and 1 7/8" tow balls

350-00060 HAYMAN REESE HITCH STEP

Designed to stay in place whilst towing, the Hitch Step mounts over your tow ball. Three simple steps is all it takes to assemble your step onto the towbar's tow ball mount. The step features a high grade aluminium body with machine cut non-slip tread, making it corrosion resistant and giving extra grip for those slippery situations.



- > Easy to install, 4 bolts and you're done
- > Fits virtually any towbar, with a flat sided tow ball mount
- > Aluminium construction that is light-weight, corrosion resistant and looks great on the back of your car
- > High-grip non-slip step, keeping you safe in the wet
- > Raised upper lip to prevent you sliding off
- > Ideal for boat owners, helps keep your feet dry when launching or retrieving your boat

Specifications

Weight Capacity: 120kg
Length: 355mm
Width: 75mm

350-00070 BLACK SHIN PROTECTOR

No more bruised shins. Made from soft rubber the shin protector fits securely over the tow bar goose neck.



350-00086 ARK DUAL PURPOSE HITCH PIN LOCK

Slimline design, can be used with or without lock, suits 50.8mm (2") x 50.8mm (2") class 4 receivers from 65mm - 80mm, comes with spring clip for extra protection, chrome plated finish, towing rating 3500kg.



SHACKLES

The current standard applying to shackles is AS 2741-2002, however this standard does not specifically cover the use of rated shackles in an application such as attaching a trailer to a tow bar. This standard covers the use of shackles for lifting purposes.

The Caravan Industry Association of Australia's recommendation is that a shackle meeting the requirements of AS 2741-2002 be used to secure rated safety chains up to 3500kg capacity.

Suitable shackles have the following specifications:

- > Meet the requirements of AS 2741-2002
- > Shackle grade is "S" or "6"
- > Working load limit (WLL) is 1000kg
- > Shackle diameter is 10mm
- > Either "bow" or "dee" shackle design is suitable, although it is noted that the "bow" design provides greater angular displacement

A significant detail to understand is that the breaking load of a shackle is generally six times the working load limit." Source: RVMAP Technical Alert - D-Shackle Confusion Resolved, 20.10.2014

**450-05000
DEE SHACKLE GALVANISED
8MM (5/16")**

Not to be used with safety chains as this is a general purpose shackle.



**450-05002
DEE SHACKLE GALVANISED
8MM (5/16")**

Rated to 0.75t



**450-05010
DEE SHACKLE GALVANISED
10MM (3/8")**

With a working load rating of 320kg and a proof load rating of 640kg. Not to be used with safety chains as this is a general purpose shackle.



**450-05012
DEE SHACKLE GALVANISED
10MM (3/8")**

Rated to 1t



**450-05020
DEE SHACKLE GALVANISED
12MM**

A working load rating of 520Kg and a proof load rating of 1040Kg. Not to be used with safety chains as this is a general purpose shackle.



**450-05022
DEE SHACKLE GALVANISED
11MM (7/16")**

Rated to 1.5t



**450-05024
DEE SHACKLE GALVANISED
13MM (1/2")**

Rated to 2.0t



HAND BRAKE SPARES

**450-05050
HAND BRAKE WIRE CABLE**

4mm x 10m length



**450-05060
HAND BRAKE CABLE
ADJUSTER**

(With Pulley)



**450-05070
HAND BRAKE CABLE
CLIPS**



**450-05080
BRAKE CABLE
PULLEY**



ALKO COUPLINGS

**450-05100
2000KG 2-HOLE SNAP ON
COUPLING (PAINTED)**

A fixed coupling suited to fit either where there are no brakes on the trailer, or the braking system does not require activation from an overrun coupling.



450-05110
2000KG 2-HOLE SNAP ON COUPLING WITH BALL ADJUSTER

Zinc plated surface, ball to first centre.



Specifications

Mounting Hole: 101.6L x 13.5W (mm)

Hole: 77mm

450-05120
3500KG ELECTRIC COUPLING WITH HAND BRAKE

A zinc plated coupling that is simple to attach to the tow ball.



Specifications

Mounting Hole: 182.5L x 55W (mm)

Diameter: 13.5mm

450-05130
2000KG MECHANICAL OVERRIDE COUPLING (NO PLATE)

A zinc plated coupling that is suited to 50mm ball types.



Specifications

Mounting Hole: 184L x 54W x 13.5 Diameter (mm)

Diameter: 137mm

450-05140
BRAKE PLATE FOR MECHANICAL OVERRIDE COUPLING

Has a painted surface.



Specifications

Mounting Hole: 184L x 54W x 13.5 Diameter (mm)

450-05146
ALKO AKS TOW BALL RETENTION PLATE

AKS anti-rotation 50mm tow ball plate for lug type tow bar 75mm wide.



450-05147
ALKO AKS HIGH RISE 50MM TOW BALL

AKS anti-rotation 50mm high rise tow ball (black).



450-05150
HYDRAULIC CONVERSION WITH 3/4" MASTER CYLINDER

Converts mechanical couplings to hydraulic couplings (a more reliable braking system), suited for vehicles with a hydraulic drum/brake set up, zinc plated.



TOWING MIRRORS

350-00322
TOWING MIRROR STRAP ON

Type To Suit 4x4's - Clips onto your existing mirror without obstructing vision, adjustable to fit mirrors in the range of 114.3 - 292.1 (mm), sold singularly.



350-00330
TOWING MIRROR REPLACEMENT PLASTIC BUCKLE



350-00332
TOWING MIRROR REPLACEMENT RUBBER STRAP



MILENCO TOWING MIRRORS

350-00402

MILENCO FALCON MIRRORS

Lightweight and strap free, these Falcon mirrors feature an aerodynamic head to limit vibration whilst towing. They're super easy to attach to your vehicle's existing side mirrors, simply position the rubber grips onto your side mirror and tighten the thumb wheels accordingly. The convex mirror head is adjustable to maximise your tow vision. The Falcon comes with a handy storage bag and is suitable for use on most 4WD's and vans e.g. Nissan Navara. Sold in pairs.



Specifications

Mirror Head: 220W x 140H (mm)
Arm: 420mm

350-00403

MILENCO GRAND FALCON CONVEX TOWING MIRROR (TWIN PACK)

The Grand Falcon Mirror offers a new design utilising a similar operation as the Milenco Grand Aero Mirror, but with using only a single thumb screw on each clamp for quick and easy fitting with a larger head, giving maximum field of view. Typically the larger field of view will show the roof, down to the wheels on the towed caravan/trailer.



Fitting is extremely simple with a single screw that clamps both the car mirror and the arm at the same time.

350-00405

MILENCO AERO 3 XXL WIDE CONVEX MIRROR (TWIN PACK)

The Aero Extra Wide Mirrors and Grand Aero Extra Wide Mirrors are the same as the Aero 3 Mirrors and the Grand Aero 3 Mirrors. This mirror has longer arms for wider caravans, RV's or travel trailers, the Extra Wide Mirrors are only available in convex.



This enables users to have a better field of vision, particularly in instances when they have a narrow car and a wide caravan.

350-00406

MILENCO GRAND AERO 3 FLAT TOWING MIRROR (TWIN PACK)

The Grand Aero 3 Mirror offers all the benefits of the Aero 3 Mirror, plus the maximum view possible, combined with very high stability. With the Grand Aero 3 Mirror it enables you to see the top and bottom of your caravan so you can avoid hazards, such as low trees branches, sign posts sticking out etc. As you would expect from Milenco, this is a very high quality product, manufactured with the best materials available.



The mirror screws are high-grade stainless steel and turn in brass inserts that will never corrode. The mirror glass is chrome safety glass, which will offer extremely long life and will not discolour after a few years.

350-00407

MILENCO GRAND AERO 3 EXTRA WIDE CONVEX TOWING MIRROR (TWIN PACK)

The Aero Extra Wide Mirrors and Grand Aero Extra Wide Mirrors are the same as the Aero 3 Mirrors and the Grand Aero 3 Mirrors. These mirrors have longer arms for wider caravans, RV's or travel trailers, the Extra Wide Mirrors are only available in convex.



The arm is approximately 41cm, as opposed to the Aero standard arm of 31cm.

This enables you to have a better field of view particularly when you have a narrow car and a wide caravan.

350-00408

MILENCO FALCON SUPER STEADY TOWING MIRROR (TWIN PACK)

The Falcon Super Steady Mirrors are quite simply the best budget mirrors money can buy.



These Mirrors are in a completely different league of engineering quality and design to other budget Mirrors. These Mirrors are superior in every way and fit easily to all vehicles. They are completely compliant with the very latest vehicle safety regulations and are approved to the new 04 series of approvals.

350-00413

MILENCO MGI SAFETY TOWING MIRROR CONVEX SINGLES

This mirror is ideal for those who tow occasionally. The MGI - Milenco Safety Mirrors are simple to fit, but more importantly, they meet all the latest Safety Regulations for Towing Mirrors. The tensioning straps and handles means they can be adjusted to fit most typical traditional car mirrors. Sold in singles



MILENCO TOWING MIRRORS SPARES

350-00411
MILENCO
REPLACEMENT AERO
PADS (2 PER PACK)

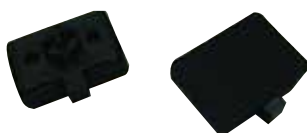

350-00412
MILENCO AERO
MIRROR HEADS
CONVEX



350-00414
MILENCO AERO
EXTRA WIDE ARMS
PAIRS



350-00415
MILENCO AERO
GRAND MIRROR
HEADS FLAT



350-00416
MILENCO AERO
GRAND MIRROR
HEADS CONVEX



350-00419
MILENCO AERO
CLAMPS



350-00500
COAST DOOR MOUNT
MIRROR

Suitable for most 4x4's, cars & vans, the Coast door mounted towing mirror is ideal for towing caravans, campers, horse floats & boats. Comes with a bonus 50mm blind spot mirror for maximum vision capability. Also includes an additional large bracket and strap to suit thicker door types. Sold singularly.



350-00502
COAST MIRROR HEAD
ONLY T/S DOOR
MOUNT MIRROR V2

Head only for Coast door mount mirror V2.





Reich made quite a name for themselves when they developed the Move Control Series of caravan movers. Now these innovative Germans have produced a range of towing mirrors designed to give you a vibration free, hassle free & obstruction free towing experience. They feature a turn knob which controls the length of the straps, ensuring maximum tightening security onto the existing car mirror.

350-00600
REICH EXCELLENT VIEW TOWING MIRROR

The pioneer in the Reich Mirror Series, adjustable clip on mirror suitable for vans, 4x4's, motor homes etc, rigid construction minimizing vibration, has rubber suckers to protect your cars mirror, has a large 20 x 13(cm) convex mirror. Sold singularly.



350-00620
REICH HANDY MIRROR XL EXTENDED

Same features as the XL mirror above but has longer arms making it suitable to tow wider & longer caravans. Sold singularly.



350-00610
REICH HANDY MIRROR XL

Features positive adjustable straps with quick release, has an adjustable mirror head, the jointed arms allow for installation on large size vehicle mirrors, has a large 20 x 13cm convex mirror. Sold singularly.



350-00640
REICH SPEEDFIX MIRROR

The name says it all! The Speedfix is a clip-on mirror with a patented rod end. The innovative fastening system, in conjunction with a semi-flex arm, ensures suitability with most 4WD and car mirrors. The rigid design and aerodynamic head ensures a vibration-free towing experience. Comes with a carry bag and is sold in pairs.



Specifications
Mirror Head: 220W x 120H (mm)
Arm: 350mm

350-01216 HAYMAN REESE COMPACT REMOTE MOUNT BRAKE CONTROLLER

Compact in size, the Compact is an electric brake controller for 1-3 axles. The main control unit is mounted out of sight, leaving the controls to be mounted on the dash of your vehicle. By installing a brake controller remotely, the install is less likely to interfere with airbag deployment and also ensures there are no issues with hitting or damaging the brake control unit. The Compact also features a "Sync Control" dial - this gives the driver more control when applying the trailers brakes. The "Sync Control" can be adjusted according to the driver's preference or road conditions. Components include: the brake control unit, a quick connect plug, a power output/manual override button, sync control and an LED indicator. Comes with a 3 year manufacturer's warranty.



350-01218 HAYMAN REESE COMPACT IQ PROPORTIONAL BRAKE CONTROLLER

The Compact IQ is the 'proportional' version of the 'time-activated' Compact brake controller (part number 350-01216 above). The Compact IQ encompasses minimalism, thanks to its super easy plug and play installation. Two dials are left on the dashboard facilitating easy operation, while the actual controller is installed behind or under the dashboard. Suitable for use with 1-3 axles, it includes a 'boost' function to give the driver the ability to set a minimum braking power. An LED indicator (one of the dials on the dashboard) constantly shows the status of the braking system. The Compact IQ is fully compatible with Electronic Stability Control systems and comes with a Hayman Reese 3yr warranty.



350-01232 TEKONSHA #9030 VOYAGER 12V BRAKE CONTROL

The Voyager has recessed controls which protect the gain and level settings from accidental readjustment. Its internal sensor measures the amount of deceleration and sends the required amount of power to the trailer brakes. Its circuitry ensures minimum interference with other electronic systems such as ABS & cruise control. The Voyager has the traditional 4-wire hook up and comes with a U-shaped bracket for permanent installation. The LED display shows a complete circuit when green and as power (whether manual or automatic) is applied, it will change colour. Suitable for single and double axle trailers.



350-01238 TEKONSHA PRODIGY P2 12V BRAKE CONTROL

Suitable for 1 - 4 axle trailers, the Prodigy P2 is a proportional style brake controller. It is designed to work in with electronic-over-hydraulic brake systems and has numerous mounting options, incorporating 360 degree vertical rotation. The Prodigy P2 adjusts itself to the terrain as you drive, making it especially handy when reversing into tough spots. It works proportionally in reverse, with the ability to disable itself when it is not needed. The "boost" feature gives users the ability to apply more braking power when towing heavier trailers/ horse floats, which also gives you more control. When not being used, the Prodigy P2 can be easily disconnected allowing for storage elsewhere.



Specifications

Weight: 590g

Dimensions: 76H x 114W x 267L (mm)

350-01246 GSL 24V ELECTRONIC BRAKE CONTROLLER

The 24V EBC has all the same features as the 12V EBC but it operates at 24V. This makes it better suited to vehicles such as trucks or imported RVs that require the higher voltage, with a 12V output to your trailer's electric brakes.



Specifications

Nominal Operating Voltage: 24VDC

No Current Load: 30mA

Dimensions: 40H x 80W x 125D (mm)

Weight: 270g

350-01250 TEKONSHA BREAKAWAY SWITCH (2010)

For trailers over 2000kg (Gross Trailer Mass) it is a requirement that a mechanism is in place in the event that if the trailer and tow vehicle separate accidentally, the trailer brakes are applied at full power for at least 15 minutes. One way to combat this is with a breakaway switch which sets the trailer brakes in case the trailer breaks away, however this is not to be used as a parking brake. Made from nylon with a weldable tab.



**350-01260
TEKONSHA SHUR-SET
III BREAKAWAY KIT**

Kit includes a 5A battery with lockable case and nylon breakaway switch and only weighs 2.5kg.



Specifications

Dimensions: 15.9L x 16.2W x 21.6H (cm)

**350-01274
BREAKSAFE REMOTE
BATTERY MONITOR**

To be used in conjunction with the Breaksafe 6000 (part #350-01280 below), this remote monitor is fitted to the tow vehicle and checks the charge condition of the Breaksafe battery each time the brakes are applied. If the battery is low, a red light will be visible on the front panel of the monitor and a buzzer will sound.



Specifications

Dimensions (mm): 63W x 22H x 49L

**350-01276
BREAKSAFE BATTERY**

A maintenance free and rechargeable sealed lead acid (SLA) battery. 12V, 7AH.



Specifications

Dimensions: 151L x 65W x 94H (mm)

**350-01280
BREAKSAFE
BREAKAWAY SYSTEM
6000**

The Breaksafe 6000 is suitable for use in caravans, trailers & horse floats. It is compact & easy to install & has easy access to the battery compartment for servicing. Its lead acid battery as well as the internal circuit board case is enclosed offering better resistance to water. Suits all electric brakes & is charged using your vehicle's battery.



BREAKSAFE ACCESSORIES

**350-01283
BREAKAWAY SWITCH
WITH COIL CABLE**

The Breaksafe Breakaway Switch now comes with a new coil cable and stainless steel quick release clip for easy connection to your towing vehicle. This also makes the connection to the tow vehicle much neater. The coil cable stretches to 1.2mts for connection to the tow vehicle and will compress to 100mm when disconnected.



**350-01285
BREAKAWAY COIL
CABLE WITH PIN AND
RELEASE CLIP**

Suitable for Breaksafe Breakaway switches only, this option is available if you already have a Breaksafe Breakaway Switch.



TEKONSHA PRODIGY SPARE PARTS

**350-01300
TEKONSHA PRODIGY MOUNTING BRACKET**

**350-01310
TEKONSHA PRODIGY POCKET MOUNT KIT**

**350-01320
TEKONSHA PRODIGY HARNESS KIT**

TOW SECURE BREAKAWAY KITS

350-01406 TOW SECURE TS2000 BREAKAWAY CONTROL + HARNESS WITH TEKONSHA SWITCH



The Tow Secure TS2000 automatically applies the trailer brakes and the trailer stop lights in the event that the trailer separates from the tow vehicle. The TS2000 uses the battery in your RV as its source of energy storage meaning that without an internal battery it is nice and compact. It features a 5m wiring harness to connect to the RVs battery which it will not draw power from while on standby

It has a wireless receiver which is housed on the dash so that the driver can monitor the battery status via LED and audible alarms. The control module performs a 'self-test' every time the tow vehicles' engine is started to ensure everything is operable and whilst towing. The control module can be paired with multiple wireless receivers - this may be required if the same trailer is towed by different vehicles.

- > Reduced size thanks to no internal battery
- > No power draw while on standby
- > 5m Wiring Harness
- > Power indicating LED

350-01408 TOW SECURE TS1500 BREAKAWAY CONTROL + HARNESS WITH TEKONSHA SWITCH

The Tow Secure TS1500 automatically applies the trailer brakes and the trailer stop lights in the event that the trailer separates from the tow vehicle.

The direct replacement for the TS1000, the TS1500 has updated electronics so that there is no draw on the internal 12v battery while on standby. This model is ideally suited for trailers that don't typically have an onboard battery such as dog trailers, box trailers and horse floats.

350-01500 TOW SECURE CHARGER

Input: 100/240VAC ~ 50/60Hz
Output: 15VDC ~ 1A Max.



350-01502 TOW SECURE RECEIVER ONLY





Sphere's new Tyre Pressure Monitoring Systems features a solar-powered LCD display wirelessly connected to four waterproof external sensors to monitor individual tyre pressure in real-time. It is the first system in Australia which can be upgraded to monitor up to 10 sensors (including 2 spare tyres) without a booster.

350-01602
SPHERE SOLAR POWERED TPMS KIT WITH 4 EXTERNAL SENSORS

The Tyre Pressure Monitoring System has visual and audible alerts when there is tyre air leakage, high tyre temperature, and too low or too high tyre pressures. The monitor also allows users to customize the high/low pressure alarm threshold by each axle. Users can set the low-pressure alarm as low as 7Psi for especially rough terrains, or change the alarm threshold for an axle taking a heavier load. When fully charged, the solar-powered LCD display battery lasts for 60 hours.

- > BAR/Psi unit setting
- > °F/°C unit setting
- > Rechargeable solar-powered display with high temperature resistant battery
- > Automatic backlight night view
- > Automatic screen brightness for clear view under strong sunlight
- > Auto-sleep function for power-saving
- > Vibration-activated auto-wake function
- > Extra USB charging port
- > One full charge lasts for 60 hours



350-01610
SPHERE - TPMS PACK OF 2 EXTERNAL SENSORS

The IP67 waterproof external sensors can withstand harsh environments and monitor real-time pressures with an impressive ± 1.5 Psi accuracy. Each external sensor is also powered by a replaceable CR1632 button battery and is made with anti-theft lock nuts to provide extra security, requiring our patented tool to remove it.



- > DIY installation
- > ± 1.5 Psi High accuracy
- > 9g external sensors, no need for wheel rebalancing
- > IP67 protection against dust and water
- > Replaceable sensor battery - CR1632 button cell.
- > 2-year sensor battery life
- > Anti-theft lock nuts included to provide extra security

QUICK FIT BIKE RACKS

350-20100**QUICK FIT XF3
FOLDING BIKE RACK -
60KG CAP**

The Quick Fit XF3 is a safe and reliable bike carrier for the transportation of 3 bicycles.

- > Suitable for almost all tow bars, all bicycles (also e-bikes) and wheel dimensions
- > An ingenious folding system makes it easy to carry and store
- > Extremely easy and quick fitting onto the tow bar with the patented quick connector
- > Boot is always accessible thanks to the easy to use tilt mechanism
- > The bicycles are held in wide, stable aluminium wheel holders
- > Flexible lockable and removable Quick Fit frame holders
- > Storage bag included
- > Lighting via a 7 plug
- > Immediate usable from the carton.
- > The bike carrier can be secured with the lock on quick connector
- > In combination with the ride-on ramp (350-20120) you can even more easily manoeuvre your bicycle onto the bike carrier

**Specifications**

Number of bicycles: 3

Tiltable: Yes

Foldable: Yes

Mounting of bicycles by lockable and removable frame holders

Weight: approx. 21 kg

Maximum load: 60 kg

Bicycle frame diameter: Ø 22 - 75 mm*

Wheel base bicycle max.: 1250 mm

Bicycle tyre width max.: 55 mm

Wheel holder distance: approx. 220mm

Colour: Black

Material: Coated steel + aluminium

350-20102**QUICK FIT XF2
FOLDING BIKE RACK -
60KG CAP**

The Quick Fit XF2 is a safe and reliable bike carrier for the transportation of 2 bicycles.

- > Suitable for almost all tow bars, all bicycles (also e-bikes) and wheel dimensions
- > An ingenious folding system makes it easy to carry and store
- > Extremely easy and quick fitting onto the tow bar with the patented quick connector
- > Boot is always accessible thanks to the easy to use tilt mechanism
- > The bicycles are held in wide, stable aluminium wheel holders
- > Flexible lockable and removable Quick Fit frame holders
- > Storage bag included
- > Lighting via a 7 plug
- > Immediate usable from the carton.
- > The bike carrier can be secured with the lock on quick connector
- > In combination with the ride-on ramp (350-20120) you can even more easily manoeuvre your bicycle onto the bike carrier

**Specifications**

Number of bicycles: 2

Tiltable: Yes

Foldable: Yes

Mounting of bicycles by lockable and removable frame holders

Weight: approx. 17 kg

Maximum load: 60 kg

Bicycle frame diameter: Ø 22 - 75 mm*

Wheel base bicycle max.: 1400 mm

Bicycle tyre width max.: 50 mm

Wheel holder distance: approx. 210mm

Colour: Black

Material: Coated steel + aluminium

350-20106 QUICK FIT PRO BIKE RACK - 60KG CAP

The Quick Fit Pro is a safe and reliable bike carrier for the transportation of 2 bicycles.

- > Suitable for almost all tow bars, all bicycles (also e-bikes) and wheel dimensions
- > Extremely easy and quick fitting onto the tow bar with the patented quick connector
- > Boot stays always accessible by an easy to use tilt mechanism
- > The bicycles are held in wide, stable plastic wheel holders
- > Mounting the bicycles with the frame, so there is no force on the pedals of the bicycle
- > Flexible and lockable frame holders
- > Lighting via a 7 plug
- > The bike carrier can be locked with lock on quick connector
- > European permission given by the RDW



In combination with the ride-on ramp (350-20124) you can even more easily manoeuvre your bicycle onto the bike carrier

Specifications

Number of bicycles: 2
Tiltable: Yes
Foldable: No
 Mounting of bicycles by lockable and removable frame holders
Weight: approx. 17 kg
Maximum load: 60 kg
Bicycle frame diameter: Ø 22 - 75 mm*
Wheel base bicycle max.: 1300 mm
Bicycle tyre width max.: 50 mm
Wheel holder distance: approx. 200mm
Colour: Silver
Material: Coated steel

* The maximum dimensions for any vehicle, including its load, are 2.5m in width and 4.3m in height. A vehicle fitted with a bicycle carrier, along with any bicycles must not exceed these limits. Rear-mounted bicycle carriers must also comply with rear overhang limits. Any rear overhang on a vehicle must not exceed 60% of the wheelbase or 3.7m, whichever is less.

QUICK FIT ASSIST RAMPS

A ramp makes effort unnecessary and bicycles can be easily manoeuvred onto the bike carrier. These ramps are suitable for Quick Fit bike carriers and are easy to fold up and store.



By placing a pin in the bike carrier's wheel holder, you can attach the ride-on ramp firmly and manoeuvre the bikes on and off easily.

350-20120 QUICK FIT XF BIKE ASSIST RAMP

350-20124 QUICK FIT PRO BIKE ASSIST RAMP

CARRY BIKES

Flexible and sturdy with a renewed design, the best-selling Fiamma bike carriers boast a new shape and colour to blend perfectly with most modern RVs.

350-02010 FIAMMA CARRY BIKE CARAVAN XLA PRO 200

Suited for mounting on the A-frame of a caravan, the XL A Pro 200 balances on top of the a-frame allowing you to open your storage compartment even with the bikes still mounted. It carries a maximum of two bicycles and is slightly smaller to accommodate shorter a-frame bars.

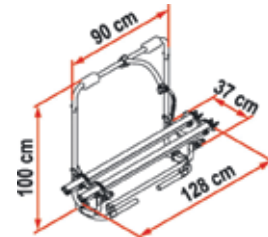

Specifications

Max Load Weight: 50kg

350-02012 FIAMMA CARRY BIKE CARAVAN XL A

A convenient and compact solution for transport of up to two bicycles. It fits all caravans with a standard A-frame and pivots forward allowing access to the storage compartment. Easily installed (no drilling required) and the rail support base has been reinforced with a new aluminium blocking system.

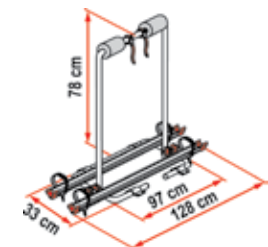
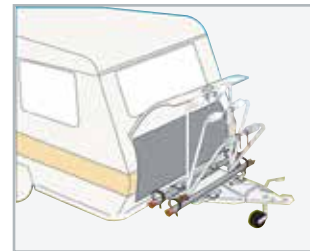

Specifications

Max Load Weight: 35kg

350-02014 CARAVAN XL A PRO 200 E-BIKE

Model designed to be installed on the caravan A-frame for carrying two E-Bikes. Suitable for all A frames.



350-02017 FIAMMA CARRY BIKE VAN 200D

An easily installed bike carrier for vans with double rear doors (no need to drill the vehicle). The wheelbase is adaptable, from 58 - 62cm, to adapt to different sized doors. Carries up to two bicycles and is suited to vehicles such as: Fiat Ducato before 1999, Ford Transit and Ford Transit (high roof).

Specifications
Max Load Weight: 35kg

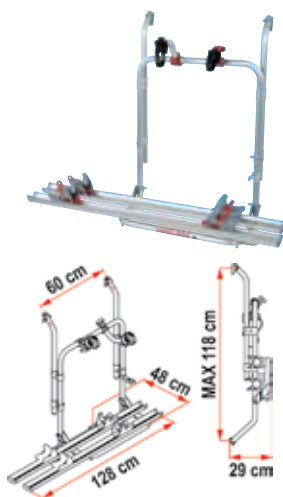

350-02020 FIAMMA CARRY BIKE BACKPACK 4X4

Best suited to minivans. The Backpack 4x4 is quickly installed onto the rear spare tyre by means of sturdy straps, however it will be necessary to remove the cover of the spare tyre. Has a folding rail support and can hold two bicycles. When installing, be sure not to cover the license plate or lights.

Specifications
Max Load Weight: 35kg

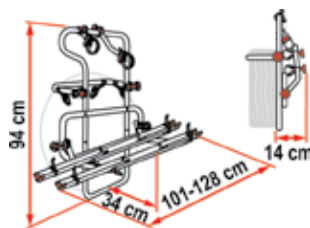

350-02042 FIAMMA CARRY BIKE PRO WITH BLACK AESTHETICS

This telescopic bike carrier, the longer version of the pro series, has a highly adjustable upper structure for better stability and is height adjustable from 80cm to 150cm. Able to carry up to 4 bicycles.

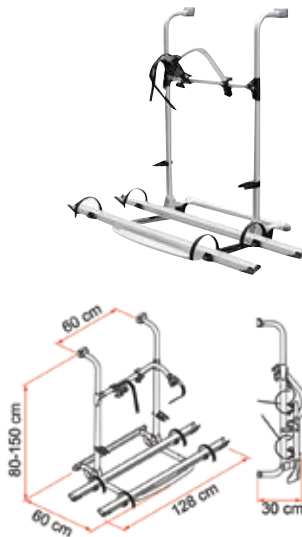

350-02044 FIAMMA CARRY BIKE PRO C WITH BLACK AESTHETICS

This compact and classic bike carrier is the short version of the pro series. It can be installed under the rear window while still allowing the window to open. The Pro C can be installed on most motorhomes and has been recommended as one of the strongest bike carriers on the market. Able to carry up to four bicycles.

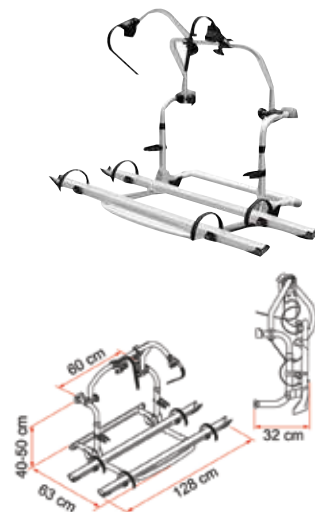

PRO SERIES E CARRY-BIKES

Two structurally sturdy models, equipped with fixed rail support base designed specifically for electric bikes, featuring the Bike Block Pro S and Rail Premium.

350-02047 FIAMMA CARRY BIKE PRO E-BIKE WITH BLACK AESTHETICS

The telescopic bike carrier, leader of Pro line, here is the special version for E-Bikes. Has a highly adjustable upper structure for better stability. The rounded tube structure is easily adjustable from 80 to 150cm in height to fit different installation requirements.

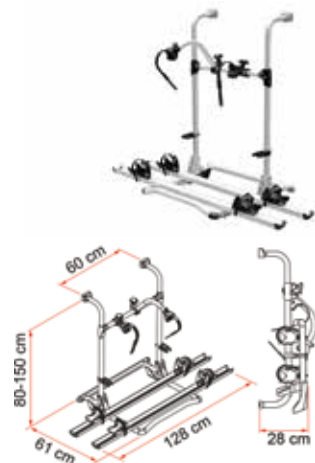

350-02048 FIAMMA CARRY BIKE PRO C E-BIKE WITH BLACK AESTHETICS

The Pro Series E-Bike carrier can be installed also under the rear window of the motorhome whilst still allowing it to open. It is the most compact on the market.

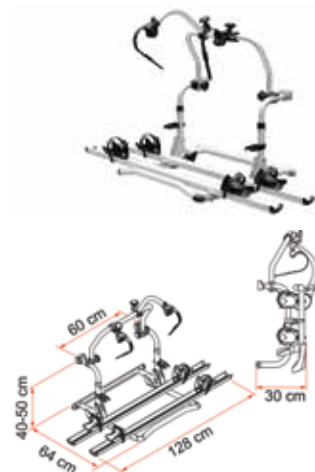

350-020623
FIAMMA CARRY BIKE
VWT5

Another one of Fiamma's best sellers, the Carry Bike VWT5 is easily installed (no drilling required) on VWT5's built after July 2003. It is designed for T5's with a single rear door and has the capacity to fit up to four bicycles.



Specifications
Max Load Weight: 60kg

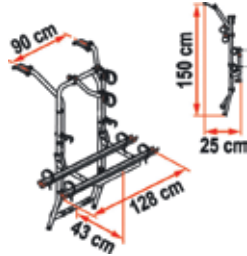

350-02087
FIAMMA CARRY BIKE
200 DJ SPRINTER

Suitable for use on vans with double rear doors, in particular, Mercedes Sprinters built after June 2006 and Volkswagen Crafters built after June 2006. This Carry Bike is installed on one of the rear doors, allowing you to gain access to the rear of your van without having to remove your bikes. It has the ability to carry up to two bikes and comes with Bike Block Pro 1 and Pro 2. No drilling is required, except for the security screws. The Carry Bike 200 DJ Sprinter weighs 9kg.

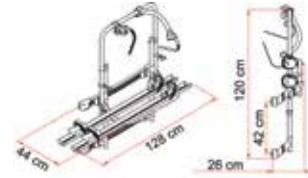

Specifications
Max Load Weight: 35kg

350-02080
FIAMMA CARRY BIKE
LIFT 77 BLACK

The Carry Bike Lift 77 lowers as much as 77cm enabling the bikes to be loaded and unloaded easily. It features exclusive Zoom-4-bikes rail support, delivered with extra-large safety straps which carry up to 60kg and a safety system that prevents accidental unhooking en-route.



350-02095
FIAMMA CARRY BIKE
200 DJ DUCATO
(AFTER JUNE 2006)

Designed for van conversions with double rear doors, the 200 DJ Ducato allows for the rail support base to be installed in 2 positions: one standard, and one at a lower height to make it easier to load the bikes. If installing in the lower position, a license plate holder must be used. The only drilling required is for the security screw. The rear doors of the Ducato can be opened without having to remove the bikes. It has the capacity to carry up to two bikes. Comes as standard with the following: x2 Bike Block Pro D1, x1 Security Strip, x2 Rail Premium, x1 Fixing Bar and Brackets. Weighs just 9kg.



Specifications
Max Load Weight: 35kg

350-02033
FIAMMA CARAVAN ACTIVE
E-BIKE

Special version specifically designed for the transportation of two electric bicycles. Thanks to the system with tensioning strap, access to the storage compartment is easy and quick.



350-02052
FIAMMA CARRY
BIKE UL

The UL is suitable for installation on motorhomes without a rear window. It is able to carry two bikes as standard, to carry a third bike (with a max load of 55Kg) an extra Bike-Block and Rail will need to be purchased. The mounting bars can be adjusted from 80-150cm, making the UL the preferred choice of many motorhome manufacturers.

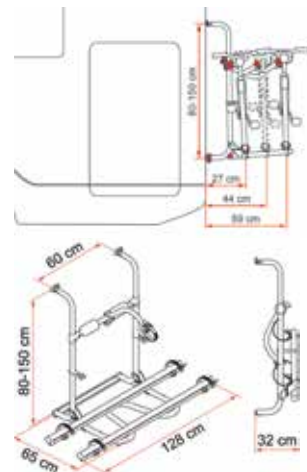

Specifications
Weighs: 5.6kg

FIAMMA CARRY BIKE ACCESSORIES

350-02210**E-BIKE REPLACEMENT RACK FOR PRO & PRO C**

Now you can turn your Carry-Bike Pro / Pro C into a E-Bike bike carrier by purchasing the new Kit Upgrade E-Bike.

Complete rail support base with two Rail Premium, structurally designed to carry two electric bicycles.

Specifications

Description	Pro E -Bike	Pro C E-Bike	XLA Pro 200
Part Number	350-02046	350-02048	350-02014
Vehicle Type	Motorhome & Caravan	Motorhome & Caravan	Caravan
Weight	10.4kg	9.9kg	10kg
Max load	60kg	60kg	50kg
Bikes Carried standard	2	2	2
Bikes carried max	2	2	2

350-02252**FIAMMA CABLE LOCK FOR CARRY-BIKE (2.5M)**

Comes with 2 keys.

**350-02290****FIAMMA BIKE - RACK RAIL (128CM)**

With Quick Strap.

**350-02295****FIAMMA BIKE-RACK RAIL WITH BLACK END CAPS AND QUICK STRAP****350-02298****FIAMMA CARRY BIKE RAIL PREMIUM (128CM)****350-02215****FIAMMA RAIL PREMIUM XL (E-BIKE)**

The XL version is longer (139cm) and suited for particularly long E-Bikes and Mountain-Bikes (with wheelbase > 125cm).

350-02320**FIAMMA BIKE BLOCK PRO - 1 RED FOR CARRY-BIKE (110MM)****Specifications**

Weighs: 0.2kg

**350-02322****FIAMMA BIKE BLOCK PRO-2 RED FOR CARRY-BIKE (230MM)****Specifications**

Weighs: 0.3kg

**350-02324****FIAMMA BIKE BLOCK PRO-3 RED FOR CARRY BIKE (375MM)****Specifications**

Weighs: 0.4kg

**350-02326****FIAMMA BIKE BLOCK PRO-4 RED FOR CARRY BIKE (530MM)****Specifications**

Weighs: 0.5kg

**350-02330****FIAMMA BIKE BLOCK PRO D-1****Specifications**

Weighs: 0.6kg

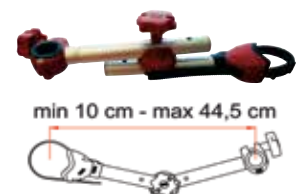
**350-02332****FIAMMA BIKE BLOCK PRO D-2****Specifications**

Weighs: 0.7kg



350-02350
FIAMMA CARRY BIKE RACK HOLDER
A locking system for added security when not carrying any bikes.



350-02520
FIAMMA BIKE COVER
(Grey Vinyl) Extra strong for caravans and covers up to two bikes.



350-02360
FIAMMA BIKE BLOCK PRO 1 BLACK



350-02362
FIAMMA BIKE BLOCK PRO 2 BLACK



350-02364
FIAMMA BIKE BLOCK PRO 3 BLACK



350-02366
FIAMMA BIKE BLOCK PRO 4 BLACK



350-02500
FIAMMA BIKE COVER PREMIUM
(Grey Vinyl) Covers up to four bikes.



350-02502
FIAMMA GREY BIKE COVER
(Grey Vinyl) Covers up to three bikes.



350-02530N
FIAMMA CARRY BIKE COVER S
Made from lightweight and waterproof polyester, the Bike Cover S has the capacity to cover up to x4 bicycles, thanks to its adjustable straps (with hooks). It comes with a transparent pocket to insert a rear signal plate. Please note, the Bike Cover S is not suitable for bike racks where the bicycles are exposed over the top of the roof.
Weighs: 1kg



HAYMAN REESE WEIGHT DISTRIBUTION SYSTEMS

Hayman Reese have been Australia's number 1 towing brand for over 60 years and that is why they back their products with a Hayman Reese Lifetime Warranty. Weight Distribution Systems (WDS) restore the geometry of the tow vehicle (such as a ute) to its natural state. A WDS transfers the weight from the rear wheels of the ute to two places: the front wheels of the ute and the wheels of the trailer. To put it simply, a good WDS will level the link between trailer and ute so it is in parallel alignment to the road.

When towing a trailer, the trailer's total ball weight is applied to the rear of your vehicle. When this happens, the front suspension of your vehicle is raised because of the added rear weight. Towing in this way can cause excess swaying of your trailer, reduced steering and breaking responsiveness, less traction and headlights that beam upwards instead of down onto the road in front of you. Over time, you may also experience reduced fuel economy and increased tyre wear (especially on the rear tyres). Hayman Reese have a number of WDS's available to improve control over your vehicle while towing and reducing the amount of sway you experience.

Use the table below to find out which Hayman Reese WDS is best for you:

Ball Weight:	RECOMMENDED WEIGHT DISTRIBUTION SYSTEM				
	Mini	Intermediate	Medium	Heavy	Super Heavy
0-80kg	✓				
80-135kg		✓			
135-275kg			✓		
275-365kg				✓	
365-545kg					✓

350-05300 HAYMAN REESE 180LB MINI

The Mini WDS is the solution for towing lighter ball weights such as a trailer. It is a two bar system (19mm diameter) which uses chains to hold the spring bars into position and can be used with any Hayman Reese towbar. It is easily setup and removed and is best suited to trailers with a ball weight up to 80kg.

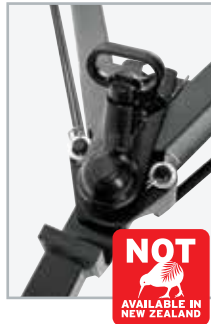

350-05310 HAYMAN REESE 285LB INTERMEDIATE

The Intermediate WDS is the solution for towing intermediate ball weights such as a camper trailer. It is a four bar system (19mm diameter) which has a working range of between 80kg and 135kg ball weights. The snap up brackets make raising and lowering the chains effortless. There are also triangular plates which allow you to adjust and equalize each pair of bars together.



350-05320 HAYMAN REESE 600LB STANDARD MEDIUM 30" SPRING BARS

The most popular towing aid in Australia which is rated for trailers that have a ball weight of between 135kg and 275kg (suitable for most popular caravans). It has a durable and light cast steel head. Its round, hook style spring bars have integrated cams which are ideal for caravans with 6" deep A-frames. It also features a Hex Cam adjustment washer which allows for up to six head-angle adjustments.



350-05330 HAYMAN REESE 600LB CLASSIC MEDIUM 30" SPRING BARS

Similar to the 600lbs Standard WDS except that the Classic WDS is composed of the Hayman Reese traditional welded head. The Classic WDS has straight, trunnion style, high performance spring bars with integrated cams and an updated lightweight (but extra durable) cast steel shank. Suitable to towing most popular caravans, it has a ball weight capacity of between 135kg and 275kg.



350-05340 HAYMAN REESE 600LB CLASSIC MEDIUM 28" SPRING BARS

This WDS has all the same features and benefits as the 600lbs Classic Medium WDS above, except that it has slightly shorter spring bars. This is to accommodate caravans or horse floats with a shorter A-frame. It is also suitable for towing most popular caravans and also has a ball weight capacity of between 135kg and 275kg.



350-05350
HAYMAN REESE
800LB STANDARD
HEAVY DUTY 30"
SPRING BARS

Suitable for towing larger and heavier trailers (such as twin axle caravans), the Standard Heavy Duty WDS relies on heavier gauge spring bars to handle the heavier load. This WDS has a ball weight capacity of between 275kg and 365kg and has 30" hook style spring bars with integrated cams. A Hex Cam adjustment washer allows for up to six head-angle adjustments, while the drop shank allows for up to six height adjustments.



DROP SHANKS AVAILABLE TO SUIT
HAYMAN REESE WEIGHT DISTRIBUTION
SYSTEMS

Hayman Reese have a range of Drop Shanks available to setup the system on 4WD's and other vehicles where the lowest/ highest setting is not low/ high enough. Please seek advice from your Coast stockist to check which Drop Shanks are compatible with your vehicle.

350-05390
HAYMAN REESE
DROP SHANK
- STANDARD

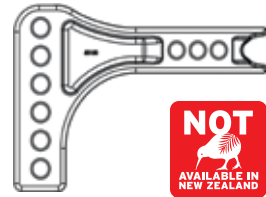

350-05360
HAYMAN REESE
800LBS CLASSIC
HEAVY DUTY 30"
SPRING BARS

Similar to the 800lbs Standard WDS except that it is composed of the Hayman Reese traditional welded head. The 800lbs Classic WDS has straight, trunnion style, high performance spring bars with integrated cams and an updated lightweight (but extra durable) cast steel shank. Suitable for towing larger twin axle caravans, it has a ball weight capacity of between 275kg and 365kg.



350-05400
HAYMAN REESE
DROP SHANK
- 30MM

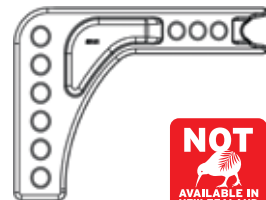

350-05370
HAYMAN REESE
800LB CLASSIC
HEAVY DUTY 28"
SPRING BARS

This WDS has all the same features and benefits as the 800lbs Classic Heavy Duty WDS except that has slightly shorter spring bars. This is to accommodate caravans or horse floats with a shorter A-frame. It is also suitable for towing most larger twin axle caravans and also has a ball weight capacity of between 275kg and 365kg.



350-05410
HAYMAN REESE
DROP SHANK
- 95MM

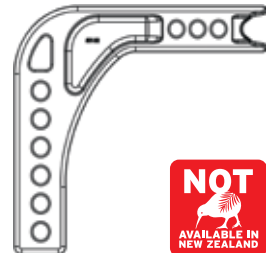

350-05380
HAYMAN REESE
1200LB SUPER
HEAVY DUTY

The Super Heavy WDS has a working ball weight range of between 365kg and 545kg. Please note however, that if you intend to carry a load in excess of 3,500kg, you will need a 70mm tow ball. Manufactured for serious heavy duty towing, it has a fine tooth adjustment washer which allows for up to nine head-angle adjustments. The drop shank allows for six height adjustments and because of the added weight, Hayman Reese have made it compatible with the Dual Cam HP Sway Control (this is available separately).



350-05420
HAYMAN REESE
DROP SHANK
- 160MM



EAZ LIFT WEIGHT DISTRIBUTION HITCHES



Over 50 years ago, Eaz Lift became the first patented weight distribution system in North America and is still the most popular WDH in the USA. Coast to Coast has recognised a product that has been tried and tested and now re-developed to suit Australian standards. It has been designed with fewer parts, making it easier to use and install. The Eaz Lift WDHs are constructed from high grade, machine tapered, round spring steel bars and are available in a 600 or 800 series. Both the 600 and 800 series include bolt-together tow ball mounts that are completely adjustable from changing tow ball heights and angles, to suit different application. The left and right sway control mounting facility is already provided should you later require a sway control kit for additional towing comfort and safety. All necessary parts come with each WDH including hook-up brackets, spring bars, chains, tow ball mount, hitch pin and a clip and bolt package for adjusting your hitch. Rated for trailer masses of up to 3.5t. Limited lifetime warranty. Please note shanks are sold separately.

350-05600**EAZ LIFT 600 SERIES**

For tow ball weights of up to 272kg - for use with a standard 7/8" (22.23) tow ball mounting hole. Shank sold separately

**350-05610****EAZ LIFT 800 SERIES**

For tow ball weights of up to 363kg - for use with a standard 7/8" (22.23mm) tow ball mounting hole. Shank sold separately.



350-05720
EAZLIFT SHANK
SOLID ADJ HI-LOW 3
HOLES 2"X12"L

The 3 hole shank combines both the LONG and SHORT shank into one unit. Can be used in either the raised or dropped position to match the ball mount to any coupler height.

Low mounted: + 45mm lift / + 135mm lift
High mounted: + 135mm lift / + 225mm lift



350-05724
EAZLIFT SHANK ADJ
EXTRA HI-LOW 3
HOLES 2"X12"L

The 3 hole shank combines both the LONG and SHORT shank into one unit. Can be used in either the raised or dropped position to match the ball mount to any coupler height.

Low mounted: - 50mm lift / + 40mm lift
High mounted: + 225mm lift / + 315mm lift



350-05728
EAZLIFT SHANK ADJ
EXTRA LOW ONLY 3
HOLES 2"X12"L

The 3 hole shank combines both the LONG and SHORT shank into one unit. Can be used in either the raised or dropped position to match the ball mount to any coupler height.

Low mounted:
- 50mm lift / - 140mm lift



350-05730
EAZLIFT BM35KAR
- ADJUSTABLE BALL-
MOUNT ATTACHMENT
W/ANTI-RATTLE
3500KG

The EazLift Adjustable Ball Mount is the ultimate height adjustable trailer hitch. It offers a huge range tow ball height adjustment, up to 680mm across EazLift's range of compatible shanks.



**Shank not included*

This simple and easy to use adjustable tow shank uses a pin and r-clip system rather than nuts and bolts allowing for effortless installation, adjustment and removal. Designed and tested in Australia, the Adjustable Ball Mount meets and exceeds ADR requirements and is rated up to 3,500kg.

- > Reversible shank and ball platform allow for a huge range of drop or rise heights
- > Up to 40 levels of adjustment across EazLift's range of compatible shanks.
- > 3,500kg Maximum Gross Trailer Mass to cover the biggest vehicle and trailer combinations utilising a 50mm Tow-Ball.
- > Designed, tested and certified for use in Australia.
- > Anti-Rattle Grub Screw
- > Genuine EazLift accessory, it is only recommended & warranted for use with genuine EazLift Shanks only.

Specifications

Designed and tested in Australia
Exceeds the design and testing requirements for AS4177.1-2004 and ADR61/02
MAX Rise 302mm when used with EazLift Extra Hi shank (350-05724)
MAX Drop 387mm when used with EazLift Extra Low shank (350-05728)
Maximum Towball Down Load: 350kg
Maximum Gross Trailer Mass: 3,500kg

SHANK SELECTION GUIDE FOR EAZ LIFT WDH'S

Step 1. Ensure that both Tow vehicle and Caravan/Horse Float/Trailer are sitting on level ground.



Step 2. Level the Caravan/Horse Float/Trailer with the aid of the jockey wheel and take the below measurements.

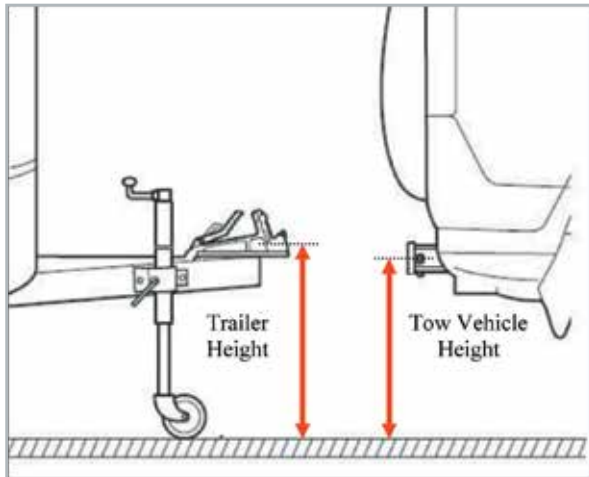

Trailer Height = 445mm
 Tow Vehicle Height = 400mm
 A +45mm lift is required from the Shank.

Example 1 445mm - 400mm = +45mm

Trailer Height	-	Tow Vehicle	=	Required Lift
----------------	---	-------------	---	---------------

Example 2 370mm - 450mm = -80mm

Trailer Height	-	Tow Vehicle	=	Required Lift
----------------	---	-------------	---	---------------

EAZ LIFT SWAY CONTROLS

Eaz Lift screw on sway controls minimise the sway caused by passing trucks and sudden gusts of wind. It works by using a double friction disc brake principle which provides constant sway reduction and therefore improves handling. They are attached with easy socket and spring clip connectors which also make them easy to remove for convenient storage. The slide bar is zinc plated which ensures consistent smooth gliding action.

Note: Trailers/ caravans over 24' may require two sway controls.

350-05800
EAZ LIFT SCREW-ON SWAY CONTROL (DRIVERS SIDE/RIGHT HAND MOUNTED)



350-05810
EAZ LIFT SCREW-ON SWAY CONTROL (PASSENGER SIDE/LEFT HAND MOUNTED)



EAZ LIFT SPARE PARTS

350-05900
EAZ LIFT BALL MOUNT FOR 2" SQ SHANK WITH LOCK CLIPS



350-05901
EAZ LIFT BALL MOUNT WITH 1-1/4" BALL HOLE



350-05902
EAZ LIFT HITCH PIN



350-05908
EAZ LIFT SPRING BAR 272KG RATING (600 SERIES)



350-05909
EAZ LIFT SPRING
BAR 363KG RATING
(800 SERIES)



350-05910
EAZ LIFT HOOK UP
WIRE CLIP 2PC FOR
48029



350-05936
EAZ LIFT CHAIN PACKAGE



350-05914
EAZ LIFT QUICK HOOK-UP



350-05916
EAZ LIFT SET SCREW
(HOOK-UP)



350-05918
EAZ LIFT BOLT PACKAGE
FOR 272-363

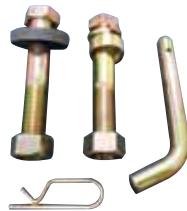

350-05920
EAZ LIFT SET SCREW
FOR 272-363 BALL MOUNT



350-05922
EAZ LIFT SPRING BAR LOCKING
DEVICE REPAIR KIT



350-05924
EAZ LIFT U-BOLT ONLY FOR
CHAIN PACKAGE SOLD PER
PAIR

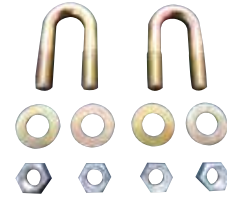

350-05925
EAZ LIFT SWAY
CONTROL BALL
MOUNT PLATE WITH
HOLE



350-05926
SWAY CONTROL
BALL, WASHER & NUT
CLAMSHELLED



350-05928
EAZ LIFT LEVEL BAR



350-05930
EAZ LIFT TRAILER
TONGUE BALL PLATE



SOME EAZ LIFT WDH QUESTIONS

How do I work out if I require the 600 or 800 series hitch?

Use the guide below to help you determine what size hitch you need:

- > Determine the ball weight of the trailer - ball weight includes the trailer ball weight with full gas, water, waste systems and a packed trailer.
- > Estimate the car boot load - be sure to include all items carried in the back of the vehicle.
- > Match the sum of these weights to the Correct EAZ-LIFT® Hitch - For example, a ball weight of 500lbs (227kg) coupled with a car boot load of 200lbs (90kg) equates total hitch weight of 700lbs (317kg).

From the guide above, this example of vehicle-trailer combination would require an Eaz Lift 800 Series WDH - 800 Series for weights higher than 272kg and up to 363kg. Make sure the ball weight and the gross trailer weight do not exceed the tow vehicle manufacturer's recommended capacities. The hitch selected must have a maximum Gross Trailer Weight rating equal to or greater than the trailer rating. Ball weight is generally 10% of gross trailer weight.

Towing Tips

All trailers, including caravans, affect the performance of the towing vehicle. They affect fuel consumption, acceleration, braking ability, general control and maneuverability. These effects worsen as the size and weight of the trailer increase relative to that of the towing vehicle. The extra length and width can be hard to manage, with wind, road roughness and passing vehicles having a greater effect than on the vehicle alone. This puts additional responsibilities on a driver.

The following information applies to vehicles not exceeding 4.5 tons gross vehicle mass (GVM).

Rules for Towing

- > Towing more than one trailer at a time is not allowed
- > Nobody is allowed to ride in trailers or caravans
- > When towing and driving on a road without street lights, drive at least 60m behind heavy vehicles or other vehicles towing trailers, unless overtaking
- > Learner drivers and learner and provisional motorcycle riders are not allowed to tow
- > P1 car license holders can tow small trailers with up to 250kg of unloaded weight.

Remember

- > Allow longer distances for braking, overtaking and joining a traffic stream
- > When reversing, it is advisable to have someone outside the vehicle giving directions
- > Look further ahead than normal so you can react to changes in traffic or road conditions
- > Use a lower gear when travelling downhill to increase vehicle control and reduce strain on brakes
- > Slow down well before entering corners and curves
- > Trailers tend to jerk the back of the vehicle around and can cause sway (snaking). If a trailer starts to sway, the vehicle's brakes should not be applied, except as an absolute last resort. If the trailer's brakes can be operated by themselves they should be applied gently, otherwise a steady speed or slight acceleration should be held if possible until the sway stops

- > Take care not to hold up traffic unnecessarily
- > Plan more rest stops and shorter travelling days as towing is more stressful and tiring than normal driving
- > There is no specific speed restriction while towing a trailer. However, the posted speed limits must not be exceeded. Always drive to the road, traffic and weather conditions.

Before each trip, check

- > Vehicle and trailer are roadworthy.
- > All tyres are properly inflated.
- > Trailer's wheel-bearings, suspension and brakes work properly.
- > All lights work and safety chains are properly connected.
- > Oil, water, brake fluid, battery and other service checks on the vehicle.

At regular intervals during the trip, check

- > Couplings, all doors, hatches, covers and any load or equipment are still properly secured.
- > If travelling to another State, check with the relevant roads authority whether there are different rules.

The Towing Vehicle

Vehicles must be suited to the trailer. Vehicle manufacturers usually indicate in the owner's manuals the maximum weight and other features of trailers appropriate for the vehicle. These limits should not be exceeded.

Registration

- > All vehicles must comply with all relevant standards for registration and be roadworthy at all times
- > Rear number plates and lights must not be obscured by the tow bar when there is no trailer connected.

Towing vehicles must be properly equipped with:

- > Tow bars and couplings of a suitable type and capacity
- > Electrical sockets for lighting
- > Brake connections if the trailer is fitted with power or electric brakes

Additionally

- > For vehicles with automatic transmission, an extra transmission oil cooler may be needed
- > Some vehicles need structural reinforcement and/or special suspension and transmission options and load-distributing devices to be able to tow heavier trailers.

Tow Bar

A properly designed and fitted tow bar is essential for towing. The rated capacity of the tow bar and coupling should not be exceeded.

The tow bar should be clearly and permanently marked with its:

- > Maximum rated capacity
- > Make and model of the vehicle it is intended for or the manufacturer's part number
- > Manufacturer's name or trade mark.

This is compulsory for vehicles built after 1 January 1992. The exception is where the tow bar is a permanent part of the vehicle.

Tow bars must not protrude dangerously when there is no trailer connected.

Load Equalizers

- > Help the vehicle retain normal suspension height and effective steering control
- > Transfer some of the weight from the tow bar to the front and rear suspension of the vehicle.

As load equalizers may overload the tow bar and its components, check with the tow bar manufacturer for advice before use.

The Trailer

Trailers must be a suitable size and type for their intended tasks. They must be built to meet the standards for registration. If a trailer is required to be registered it must be fitted with a rear number plate.

Towing Ratio Requirement

The loaded mass of the trailer must not exceed the lesser of:

- > Rated capacity of the tow bar and tow coupling.
- > Maximum towing capacity of the vehicle.
- > Maximum carrying capacity of the trailer.
- > Maximum rated carrying capacity of the tyres.

If the vehicle manufacturer has not specified the maximum towing mass, the maximum towing mass is:

- > One and a half times the unladen mass of the towing vehicle, provided that the trailer is fitted with brakes which are connected and in working order, or
- > The unladen mass of the towing vehicle if the trailer does not require brakes. Vehicles with a manufacturer's gross combination mass (GCM) more than 4.5 tons may tow in accordance with the above requirements. The GCM is the gross combination mass of the car and loaded trailer.

Braking System

The minimum braking system for a trailer depends on the type of trailer, its weight and the weight of the vehicle:

- > 0 - 750 kg loaded weight - no brakes required.
- > 751 - 2000 kg loaded weight - braking on both wheels on at least one axle.
- > 2001- 4500 kg loaded weight - braking on all wheels, and an automatic breakaway system in case the trailer becomes detached from the vehicle.

Brakes must be operable from the driver's seating position.

Towing Coupling

All couplings:

- > Must be strong enough to take the weight of a fully loaded trailer.
- > Should be marked with the manufacturer's name or trade mark and rated capacity.
- > Must be equipped with a positive locking mechanism. The locking mechanism must be able to be released regardless of the angle of the trailer to the towing vehicle.

Safety Chains

- > Must comply with Australian Standards.
- > Trailers less than 2500kg when loaded must be fitted with at least one safety chain.
- > Trailers over 2500kg when loaded must be fitted with two safety chains.

To prevent the front end of the drawbar from hitting the ground if the coupling is disconnected, safety chains must be:

- > As short as practicable and connected to the towing vehicle.

- > Crossed over if two chains are fitted.

Loading Trailers

It is important that trailers are not overloaded and that loads are properly secured to or contained within the trailer:

- > A load must not project more than 150mm beyond the trailer's width or be more than 2.5m overall width, whichever is less.
- > Loads that project more than 1.2m behind a trailer must have a red flag attached to the end of the load. This flag must be at least 300 mm square and clearly visible. To avoid having an overhanging load, you should purchase a trailer that suitably contains the load.
- > Overall length of the vehicle and trailer combination including its load must not be more than 19m.
- > To reduce sway, heavy loads should be concentrated towards the centre of the trailer.
- > Loads should be kept as low and as close as possible to the axle or axles with about 60% of the total weight forward of the centre of the axle or axles. As a general rule, about 5-10% of the total mass of the trailer plus load should be supported by the vehicle through the coupling. The trailer drawbar should be level or slightly 'nose down'.

Source: <http://www.rms.nsw.gov.au/roads/safety-rules/road-rules/towing.html>
(11 June 2015)

RV COASTER



Where will it take you?

Folding bikes offer a great solution to those who enjoy a bike ride, but have limited storage space. Whether you live in an apartment or frequently travel, the RV Coaster provides an alternative mode of transport that you can take with you – on a train, plane or RV! And, if you hide a component (let's say a seat) in a different spot to your bike, stealing it is going to be, well, painful! Don't be fooled either by the size of the RV Coaster. Many people think that suspension or quality is compromised when producing a folding bike but rest assured this is not the case with the RV Coaster. Tyre technology and frame materials have advanced to a point where the quality of a folding bike can be compared to its bulkier and more rigid members of the 2-wheeled variety.

The RV Coaster has the following enviable features:

- > Six Gears - the more gears, the easier it is to control your speed over a variety of terrains, just like your car!
- > Clipless Pedals - no annoying straps or buckles to tie over your shoes, but they do have reflectors which makes your visibility to other road/path users easy
- > Kickstand
- > Shimano Gears and Grip Shifter - just like on Norco and other full-sized bikes
- > Hi-tensile steel frame
- > 20" Aluminium Alloy rims
- > 20" x 1.5" rubber/butyl tyres

Specifications

Weight: 16.7kg

Max Weight Capacity: 100kg

Folded Size: 84L x 34W x 64H (cm)

Open Size: Handlebar to Floor: 105cm

Seat to Floor: 71-89cm

Length: 146cm

350-06530

RV COASTER FOLDING BIKE
- WHITE

350-06532

RV COASTER FOLDING BIKE
- SILVER

PEDALBOX ELECTRONIC THROTTLE CONTROLLER RANGE

2

THROTTLE CONTROLLERS



PedalBox throttle controllers are the newest tool to help you drive smoothly and more effectively. They remove delays in the accelerator to help you manoeuvre your car easily, even when towing or on difficult terrain!

Our throttle controllers alter the acceleration curve on electronic throttle controlled vehicles. They digitally alter the shape of the curve increasing throttle response and improving your overall driving experience. There are four driving modes, Off, Sport+, Sport and Eco/City and each mode can be optimised by a further six levels of curve control. This means that the settings can be adjusted to best suit your driving style.

- > A huge range of cars, 4WDs, vans and trucks supported
- > Improved throttle response for all vehicle types
- > Simple installation and removal—leave no trace
- > Made in Germany for quality guarantee
- > Two year warranty for peace of mind

Part Number	Description
350-13735	PedalBox Throttle Controller For Mitsubishi Challenger 2.5CRD/Triton 2.5CRD/Pajero 3.2CRD.
350-13762	PedalBox Throttle Controller For Toyota LC76,78,79 D4-D No Airbag / Hilux D4-D / Prado 120 D4-D / FJ Cruiser. 3762

Part Number	Description
350-13701	PedalBox Throttle Controller For Toyota Hilux/Fortuner 2.8 CRD. 3701
350-13705	PedalBox Throttle Controller For Ford Ranger-Mazda BT-50 2.5 & 3.0 CRD. 37005
350-13706	PedalBox Throttle Controller For Nissan Navara-Pathfinder 2.5CRD&3.0CRD V6/ Holden Colorado
350-13708	PedalBox Throttle Controller For VW Amarok 2.0CRD/Porsche Cayene(All)Ford Territory 2.7CRD
350-13724	Toyota LC200/ 76,78,79 V8 D4-D with airbag Prado 150 D4-D / Isuzu D-Max & MUX 3.0 CRD 2012 on. 3724

