

# SECTION 7

## PLUMBING

(Product Group - 800)

Shurflo Pumps and Parts	240 - 243
Lockable Water Fillers	245 - 246
Waste Hose and Drinking Hose	246 - 248
Water Tanks	248 - 251
JG Plumbing Fittings	251 - 256
Plastic Plumbing Fittings	256 - 259
Fuel Safe Cans	260
Accumulator Tanks	260
Tank Monitors and Cleaners	260 - 261
Thetford Sinks, Smev Sinks and Acrylic Sinks	261 - 264
Shower Hoses, Mixers and Hand Pumps	264 - 266
Shower Bases and Bathroom Modules	266
Faucets	266 - 267



---

## TOILETS

(Product Group - 850)

Fiamma Bipots and Thetford Porta Pottis	268 - 269
Thetford Additives Cleaners	270 - 272
Toilet Tissue	272
Thetford Cassette Toilets	273 - 274
Thetford Toilet Accessories and Spares	274 - 276
Valterra Hoses, Valves and Fittings	276 - 277
Camco Sewer Fittings and Hoses	277 - 279
Fiamma Waste Tank	279
Caravan Loo Treatment	279 - 280
Toilet Deodorisers	280 - 281



SHURFLO PUMPS



Since 1968, SHURFLO® emerged to set the standard for all freshwater pumps throughout the RV Industry. Used worldwide, SHURFLO® pumps quickly earned the reputation of being the most reliable on the market.

**800-00012**  
**SHURFLO PUMP 12V**  
**(10L, OEM BULK,**  
**NO FITTINGS)**

A fresh water pump designed with a one-piece diaphragm and internal by-pass ensuring a long life and max performance. Constructed for high flow demand, this updated Shurflo pump has low noise emissions and no rapid cycling. CE and C-Tick compliant, must be installed with a filter.



**Specifications**

- Pump**
- Type:** 4 Chamber Diaphragm Pump
- Ports:** 1/2" - 14 NPSM-Male
- Inlet PSI:** 30Psi (2.1Bar) Max
- Shut Off Pressure:** 45Psi
- Electrical**
- Motor:** 12V DC Permanent Magnet, Intermittent Duty
- Protection:** Thermal Overload, Automatic Restart
- Fuse:** 7A Recommended
- Materials**
- Housing:** Polypropylene
- Hardware:** Stainless and Zinc Plated Steel
- Net Weight:** 2.3kg
- Dimensions:** 205L x 125W x 111H (mm)

**800-99997**  
**SHURFLO 4009 OEM PUMP 12V AND FILTER KIT**  
 Includes x1 800-00012 and x1 800-00300

**800-00022**  
**SHURFLO 4009 PUMP**  
**(10L, RETAIL BOX)**

Has all the same features and functions as 800-00012 (above) with the only difference being that it comes in a well presented retail box with fittings for display on your shelves. The Retail Box comes with x2 800-00206 fittings for your customers' convenience.



Note: A filter must be installed with the 4009 Pump in order to validate warranty.



**800-99998**

**SHURFLO 4009 RETAIL PUMP 12V AND FILTER KIT**

Includes x1 800-00022 and x1 800-00300

**800-00052**

**SHURFLO 4009 PUMP 24V (10L OEM BULK, NO FITTINGS)**

Has all the same features and functions as 800-00012 with the only difference being that it runs on 24VDC. Note: A filter must be installed with the 4009 Pump in order to validate warranty.



**Specifications**

**Pump**

Type: 4 Chamber Diaphragm Pump

Ports: 1/2" - 14 NPSM-Male

Inlet PSI: 30Psi (2.0Bar) Max

Shut Off Pressure: 30Psi

**Electrical**

Motor: 24V DC Permanent Magnet, Intermittent Duty

Protection: Thermal Overload, Automatic Restart

Fuse: 5A Recommended

**Materials**

Housing: Polypropylene

Hardware: Stainless and Zinc Plated Steel

Net Weight: 2.5kg

Dimensions: 205L x 125W x 111H (mm)

**800-00072**

**SHURFLO 30PSI 12V PUMP RETAIL BOX**

Has all the same features and functions as 800-00070 with the only difference being that it comes in a well presented retail box with fittings. This retail box also contains all the necessary fittings for installation, however please note, a filter must be installed with the 4009 pump in order to validate warranty.



**SHURFLO 2088 REPLACEMENT PARTS**

**800-00150**

**REPLACEMENT VALVE ASSEMBLY KIT**



**800-00152**

**REPLACEMENT PLASTIC BASE PLATE**



**800-00154**

**REPLACEMENT CHECK VALVE KIT**



**800-00156**

**REPLACEMENT LOWER HSG/DRIVE KIT**



**800-00158**

**REPLACEMENT UPPER HSG/SWK KIT 40PSI**



**800-00070**

**SHURFLO 30PSI 12V PUMP BULK**

Shurflo's 4009 series fresh water pump design was created with a unique one-piece diaphragm and internal by-pass, assuring long life and top performance. The 4009 series pump is constructed for high flow demand, low noise and no rapid cycling. The 4009 series fresh water automatic demand pump is super quiet, thermally protected and can run dry without damage. Note: A filter must be installed with the 4009 pump in order to validate warranty.

**Specifications**

**Pump**

Type: 4 Chamber Diaphragm Pump

Ports: 1/2" - 14 NPSM-Male

Inlet PSI: 30Psi (2.1Bar) Max

Shut Off Pressure: 30Psi

**Electrical**

Motor: 12V DC Permanent Magnet, Intermittent Duty

Protection: Thermal Overload, Automatic Restart

Fuse: 5A Recommended

**Materials**

Housing: Polypropylene

Hardware: Stainless and Zinc Plated Steel

Net Weight: 2.3kg

Dimensions: 205L x 125W x 111H (mm)

**SHURFLO 4009 REPLACEMENT PARTS**

**800-00160**  
REPLACEMENT UPPER  
ASSEMBLY #1



**800-00162**  
REPLACEMENT VALVE ASSEMBLY  
#2



**800-00164**  
REPLACEMENT DRIVE ASSEMBLY #3

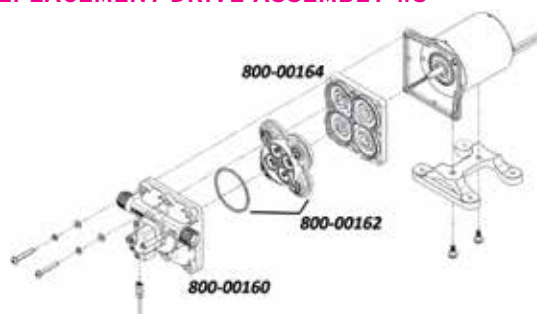

**800-00170**  
SHURFLO PRESSURE SWITCH  
To suit 4009-101-A87/B87.94-890-02



**800-00172**  
SHURFLO UPPER ASSEMBLY #1  
To suit 4009-131-A54 24V pump

**SHURFLO BARBS**

**800-00200**  
ELBOW BARB WITH 1/2" TAIL  
(90°)



**800-00202**  
STRAIGHT BARB WITH 1/2" TAIL



**800-00204**  
ELBOW 1/2" THREAD INLET  
AND OUTLET



**800-00206**  
STRAIGHT WINGNUT WITH 3/4"  
BARB

**FILTERS**

These clear strainers eliminate unnecessary repair by keeping dust or other particles out of your Shurflo pump. Its transparent design is also convenient as it shows when the filter should be cleaned/emptied. The top housing is made from polypropylene and the filter itself is made from T304 stainless steel (mesh). Note that for warranty purposes, all Shurflo pumps must be installed with one of the two filters below.

**800-00300**  
TWIST FILTER WITH  
1/2" THREAD INLET AND  
OUTLET

This is a direct screw on filter and will require a screw-on connection.



**800-00312**  
TWIST-ON FILTER WITH  
1/2" BARB INLET

Suitable for use when a flexible hose such as a reinforced drink water hose is used.

**IN LINE CHECK VALVES**

**800-00340**  
SHURFLO IN LINE CHECK  
VALVE WITH 1/2" BARBS



**800-00350**  
WHALE 1/2 PLASTIC  
IN LINE NON RETURN  
VALVE





## SHURFLO WATER PRESSURE REGULATORS

**800-00502**

### SHURFLO IN-LINE PRESSURE WATER REGULATOR (WHITE)

A water pressure reducing valve; outlet pressure: 50psi; inlet pressure: 125psi (max)



**800-00520**

### SHURFLO CITY WATER PRESSURE REGULATOR FLUSH MOUNT (POLAR WHITE)



**800-00529**

### PRESSURE LIMITING VALVE 350KPA



**800-00532**

### SHURFLO FLUSH MOUNT WATER PRESSURE REGULATOR - BLACK



**800-00550**

### COAST 90D ELBOW HOSE ADAPTER 1/2" MPT TO CLICK ON

This quick click on hose connector has an American thread to fit properly into a Shurflo city water entry, with an elbow to prevent hose kinking.



**800-00552**

### VALTERRA MALE HOSE MENDER

Adapter to suit USA thread.



**800-00600**

### SHURFLO RV AND MARINE FILTRATION KIT (RV-QBR-A)

Using only the highest quality approved materials, the Shurflo Filtration Kit ensures you have clean, great tasting water wherever you travel. It actively reduces the chlorine taste and odour from water. The kit includes a 1/4" filter head (with bracket), a disposable filter, a drinking water tap, mounting screws, mounting fittings and a 1.5m length of tube. Suitable for cold water only, it is recommended that after prolonged periods of non-use, that the system be flushed thoroughly i.e. let water run for 2-3 minutes before using it. When mounting the system, allow 1 1/2" (38mm) clearance below the housing or 279mm below the filter head (this will give you enough room to change the filter cartridges). Comes with a limited 1yr warranty from Pentair Water Australia.



#### Specifications

Micron: 0.5

Pressure Range: 30 - 125 PSI (2.1 - 8.62 Bar)

Flow Rate: 1.9L p/min

**800-00650**

### SHURFLO REPLACEMENT CARTRIDGE FOR FILTER KIT (RV-QDFR-A)

Easily installed, the disposable quick change filter ensure you have pure water for longer. Shurflo recommends changing the filter every 6 - 12 months or when its capacity (1890L) has been reached, whichever comes first. (Alternative model number: 155 785-38)



## SHURFLO PUMP FACTS

## MAINTENANCE

Checking and cleaning the strainer, normal sanitizing and winterizing and occasional checking all plumbing hardware and fittings for tightness is all that is normally required. Lack of sanitizing is the number one reason for premature pump failure and poor performance over time. Lack of sanitizing will cause scale build-up on the diaphragm and valves, causing low flow and leak back (occasionally pump cycling with no faucets open or tank filling up when hooked up to city water).

## SANITIZING

Potable water systems require periodic maintenance to keep components working properly and deliver a consistent flow of fresh water. Sanitizing is recommended: prior to storing, after a period of storage, or any time the system is opened or contaminated, as follows: NOTE: Check your Vehicle Owner's Manual for specific instructions. By-pass any filters or remove filter cartridges.

1. Determine the amount of common household bleach needed to sanitize the tank. 1 ml bleach per 1 liter tank size: 300 liter tank = 300 milliliters of bleach.
2. Mix the bleach with water in a container such as a gallon jug. If tank is filled through a pressurized fitting, pour the bleach into the hose before attaching the hose to the city water entry.
3. Pour the bleach solution into the tank and fill the tank with potable water. Rock the RV back and forth to coat top and sides of potable water tank.
4. Open all faucets (Hot & Cold) allowing the water to run until the odor of chlorine is detected. Allow four (4) hours of contact time to disinfect completely. Doubling the solution concentration allows for a contact time of one (1) hour.
5. Drain the tank. Refill the tank and flush the system once or twice until the odor has decreased. The residual chlorine odor and taste is not harmful.

## WINTERIZING

**Refer to the vehicle owner's manual for specific winterizing instructions.**

If water is allowed to freeze in the system, serious damage to the plumbing and pump may occur. Failures of this type will void the warranty. The best guarantee against damage is to completely drain the pump and perform the following:

1. Drain the water tank. If the tank doesn't have a drain valve, open all faucets allowing the pump to operate until the tank is empty.
2. Open all the faucets (including the lowest valve or drain in the plumbing), allow the pump to purge the water from the plumbing, and then turn the pump OFF.
3. Using a pan to catch the remaining water, remove the plumbing at the pump's inlet/outlet ports. Turn the pump ON, allowing it to operate until the water is expelled. Turn OFF power to the pump once the plumbing is emptied. Do not reconnect the pump plumbing. Make a note at tank filler as a reminder: "Plumbing is disconnected".
4. All faucets must be left open to guard against any damage.

5. Potable anti-freeze may be poured down drains and toilets to protect p-traps and toilet seals. Sanitize the plumbing system before putting the plumbing system back in service.

## PUMP W/ ADJUSTABLE PRESSURE SWITCH "OPERATION"

Restrictions in a plumbing system may cause the pump to rapid cycle (ON/OFF within 2 sec.) during low flow demands. Cycling should be minimized to prevent pulsating flow and to achieve maximum pump life. To determine if adjustment is necessary, turn tap on to lower than average flow of water. The pump should cycle, but its "OFF time" must be 2 seconds or longer. If the cycling is correct, leave well enough alone. If the pump is cycling rapidly increase the setting by turning the screw clockwise (1/2 TURN to . TURN MAX.) until the pump operates for 1 second with at least 2 seconds "OFF time". If cycling cannot be minimized consider removing plumbing restrictions or simply install a SHURFLO Accumulator.

## PUMP W/ ADJUSTABLE BYPASS &amp; ADJUSTABLE PRESSURE SWITCH "OPERATION"

The pump operates normally up to about 1 Bar [15 psi] by-pass pressure, where a spring-loaded by-pass valve opens, allowing flow back from the output side to the input side, providing smooth, steady flow with virtually no cycling, all the way down to a trickle. As a faucet is opened, the pressure will drop, the by-pass will close and full flow is achieved. This allows good flow, even with today's commonly used restrictive showers and pullout sprayer faucets. Performance will vary, of course, depending on the voltage to the pump: lower voltage = lower flow, higher voltage = higher flow. Always be cautious and practice electrical safety. It is always best to shut off power to the pump when leaving the RV/Caravan unattended.

## ABOUT THE BY-PASS

The by-pass is a spring-loaded diaphragm that, when open allows water from the discharge side back to the inlet side. If the switch or by-pass are adjusted too much, the by-pass and switch shut-off can overlap and THE PUMP WILL NOT SHUT OFF. Screwing the switch screw in clockwise will raise the shut-off pressure. Unscrewing the switch screw counter clockwise will lower the pump shut-off pressure. Screwing the by-pass screw in will raise the pressure at which the by-pass starts and raise the full by-pass pressure. Unscrewing the by-pass screw counter clockwise will lower the pressure at which by-pass starts and lower the full by-pass pressure.

**WARNING: If full by-pass is reached before the shut-off setting, the pump will not shut off .**

Full by-pass pressure setting should be at least 0.48 bars [7 psi] higher than pump shut off pressure.

## TROUBLESHOOTING

Vibration induced by driving can loosen plumbing, strainers and pump hardware.

Check for system components that are loose. Also, refer to the chart below for trouble-shooting tips.

## PUMP WILL NOT START/ BLOWS CIRCUIT

- > Electrical connections, fuse or breaker, main switch, and ground connection.

## LOCKABLE WATER FILLERS

- > Is the motor hot? Thermal breaker may have triggered; it will reset when cool.
- > Is voltage present at the switch? Bypass pressure sw. Does the pump operate?
- > Charging System for correct voltage (10%) and good ground.
- > For an open or grounded circuit, or motor; or improperly sized wire.
- > For seized or locked diaphragm assembly (water frozen?).

**WILL NOT PRIME/SPUTTERS**

(No discharge/Motor runs)

- > Is the strainer clogged with debris?
- > Is there water in the tank, or has air collected in the hot water heater?
- > Is the inlet tubing/plumbing sucking in air at plumbing connections (vacuum leak)?
- > Is inlet/outlet plumbing severely restricted or kinked? Restrictive valves?
- > Proper voltage with the pump operating ( >10%).
- > For debris in pump inlet/outlet valves or swollen/dry valves.
- > Pump housing for cracks or loose drive assembly screws.

**RAPID CYCLING**

- > For restrictive plumbing and flow restrictions in faucets/shower heads.
- > Water filter/purifier should be on separate feed line.
- > Shut-off pressure set too low.

**PUMP WILL NOT SHUT-OFF / RUNS WHEN NOZZLE IS CLOSED**

- > Output side (pressure) plumbing for leaks, and inspect for leaky valves or toilet.
- > For air trapped in outlet side (water heater) or pump head.
- > For correct voltage to pump ( >10%).
- > For loose drive assembly or pump head screws.
- > Are the valves held open by debris or is the rubber swollen?
- > Pressure switch operation. By-pass set higher than shut-off.

**NOISY OR ROUGH OPERATION**

- > For plumbing which may have vibrated loose.
- > For a restricted inlet (clogged strainer, kinked hose, restrictive valves).
- > Is the pump plumbed with rigid pipe causing noise to transmit?
- > Does the mounting surface amplify noise (flexible)? Does it bang like a drum?
- > For mounting feet that are loose or are compressed too tight.
- > For air in the system. Check all fixtures for air and bleed system.
- > The motor with pump head removed.

Is noise from motor or pump head?

**LEAKS FROM PUMP HEAD OR SWITCH**

- > For loose screws at switch or pump head.
- > Switch diaphragm ruptured or pinched.
- > For punctured diaphragm if water

**800-00900****LOCKABLE WATER FILLER COMPLETE WITH CAP AND KEYS "WHITE" 25MM OUTLET****800-00902****LOCKABLE WATER FILLER WITH 25MM OUTLET, COMPLETE WITH CAP - BLACK****Z800-01063****WATER FILLER CAP (BLACK)**

Lockable, comes with two keys.

**Z800-01064****WATER FILLER CAP (WHITE)**

Lockable, comes with two keys.

**800-00920****SPARE CAP AND KEYS ONLY "WHITE"****800-00922****SPARE CAP AND KEYS - BLACK ONLY****800-00932****LOCKABLE FUEL FILLER**

Available in white and comes with two keys.



**800-01000**  
**AC41 WATER FILLER WITH LID**



**SQUARE LOCKABLE WATER FILLER**

**800-01081**  
**DUAL LOCKABLE**  
**WATER FILLER WITH**  
**PLASTIC VALVE**



**Specifications**

Dimensions Overall: 195W x 167H x 47D (mm)

Dimensions Cut Out: 147W x 118H (mm)

**800-01082**  
**SPARE KEY TO SUIT**  
**DUAL LOCKABLE WATER**  
**FILLER**

Also suits external shower unit  
 800-06000 and 800-06002



**800-01088**  
**WATER FILLER INLET**  
**(BLACK)**

**Specifications**

Dimensions: 230W x 153H x 83D (mm)



**800-01090**  
**WATER FILLER INLET**  
**(WHITE)**

**Specifications**

Dimensions: 230W x 153H x 83D (mm)



**800-01110**  
**WATER FILLER**  
**LOCKABLE**

Accepts a 32mm or 35mm  
 hose and has a tank vent  
 connection. Is UV and impact  
 resistant and can be painted if  
 required.



**Specifications**

Dimensions Overall: 165H x 152W x 76D (mm)

Dimensions Cut Out: 121H x 108W (mm)

**800-01091**  
**DOOR SET FOR WATER**  
**FILLER INLET**



**800-01092**  
**INLET CONNECTOR FOR**  
**WATER FILLER**



**800-01096**  
**KEYS (PAIR) ONLY**  
**(PLASTIC) FOR WATER**  
**FILLER**



**800-01230**  
**MARINE AND OUTDOOR**  
**WATER HOSE**

A 10m drink water hose supplied  
 on a manually retractable hose  
 reel. Great for any RV, the hoses'  
 reinforced core ensures continuous  
 water flow. Compact in design (just  
 15.9cm wide), it has a carry handle  
 for portability. (The hose comes  
 standard with a 3/4" BSP threaded  
 connection. Should this type of  
 thread not be suited to your needs,  
 an Adaptor Kit can be purchased -  
 (refer to part number 800-01241 below)



**Specifications**

Dimensions: 1.59W x 1000L (cm)

**FLAT-OUT HOSES**

**800-01250**  
**FLAT OUT 15M DRINK**  
**HOSE 25MM ID**  
**(ON MULTI-REEL)**



**Specifications**

Dimensions: 375W x 440H (mm)

**800-01260**  
**FLAT OUT 10M DRINK**  
**HOSE 25MM ID**  
**(ON COMPACT REEL)**



**Specifications**

Dimensions: 300W x 360H (mm)



**800-01270**  
**FLAT OUT 9M WASTE**  
**HOSE 25MM ID**  
**(ON MULTI-REEL)**

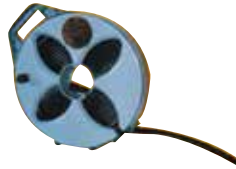

**Specifications**  
Dimensions: 375W x 440H (mm)

**800-01280**  
**FLAT OUT 6M WASTE**  
**HOSE 25MM ID**  
**(ON COMPACT REEL)**



**Specifications**  
Dimensions: 300W x 360H (mm)

**800-01290**  
**FLAT OUT 9M WASTE**  
**HOSE 32MM ID**  
**(ON MULTI-REEL)**

*\* Empty reels also available,  
please refer to Section 3*



**Specifications**  
Dimensions: 375W x 440H (mm)

**DRINKING WATER HOSE (WHITE)**

**800-01300**  
**WHITE NON-TOXIC**  
**REINFORCED WATER HOSE**  
**(12MM X 20M)**



**800-01310**  
**WHITE NON-TOXIC**  
**REINFORCED WATER HOSE**  
**(12MM X 10M)**



**WASTE HOSE 27MM ID**

**800-01340**  
**WASTE HOSE 27MM ID**  
**X 30M ROLL**  
Corrugated internally.



**BLACK WASTE HOSE 25MM ID**

Corrugated flexible hose, tough and durable waste hose with a "smooth" inner lining to prevent clogging available in 10m or 30m rolls with a 25mm ID diameter.

**800-01332**  
**10M ROLL BLACK**  
**WASTE HOSE 25MM**  
**ID**



**800-01342**  
**30M ROLL BLACK**  
**WASTE HOSE 25MM**  
**ID**



**BLACK WASTE HOSE 27MM ID**

Corrugated flexible hose, tough and durable waste hose with a "smooth" inner lining to prevent clogging available in 10m or 30m rolls with a 27mm ID diameter.

**800-01334**  
**10M ROLL BLACK WASTE**  
**HOSE 27MM ID**



**800-01344**  
**30M ROLL BLACK WASTE**  
**HOSE 27MM ID**

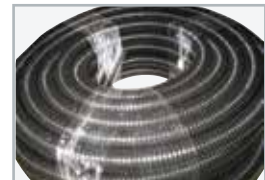

**800-01336**  
**BLACK WASTE HOSE**  
**38MM ID**

A smooth bore (inner lining) waste hose made from black PVC. It has great flexibility and is UV stabilised. Comes in a 10m roll.



**Specifications**  
Nom O.D.: 45mm  
Vacuum Rating: 310mm hg (@20°C)  
Min. Bend Radius: 140mm

### 800-01346 BLACK WASTE HOSE 32MM ID

A smooth bore waste hose made from black PVC. It has great flexibility and is UV stabilised. Comes in a 10m roll.



#### Specifications

Nom O.D.: 39mm  
Vacuum Rating: 310mm hg (@20°C)  
Min. Bend Radius: 115mm

### 800-01360 20M ROLL OF NON-TOXIC REINFORCED WATER HOSE

A blue 20m plastic wrapped hose suitable for multiple applications, especially in caravans and boats. Can also be used with a standard 12mm garden hose fitting.



#### Specifications

Pressure Rating: 12.5PN

### 800-01362 10M ROLL OF NON-TOXIC REINFORCED WATER HOSE

A blue 10m plastic wrapped hose suitable for multiple applications, especially in caravans and boats. Can also be used with a standard 12mm garden hose fitting.



#### Specifications

Pressure Rating: 12.5PN

### 800-01364 100M COIL OF NON TOXIC REINFORCED WATER HOSE

A blue 100m plastic wrapped hose suitable for multiple applications, especially in caravans and boats. Can also be used with a standard 12mm garden hose fitting.



#### Specifications

Pressure Rating: 12.5PN

### 800-01366 12MM WHITE NON TOXIC WATER HOSE WITH FITTINGS 10M

12mm hose for the conveyance of drinking water, comes with fittings installed.

- > Proudly Australian made.
- > Conforms to AS/NZS 2070 (Plastics for food contact).
- > Excellent U.V. resistance to withstand extreme Australian conditions.
- > Manufactured from Phthalate free compound.
- > Specially manufactured as to not taint the water.



#### Specifications

Inner Core: White non tainting Polyolefin with smooth finish.  
Reinforcing: High tenacity polyester yarn.  
Outer Cover: U.V. stabilised clear Polyolefin with a smooth finish.  
Fittings: Fitted with Perma-connect fittings c/w tap adaptor.

### 800-01500 ALKO TANK

52L Alko tank

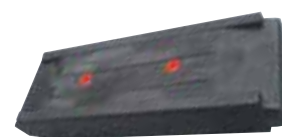

#### Specifications

Dimensions: 1000mm x 330mm x 178mm

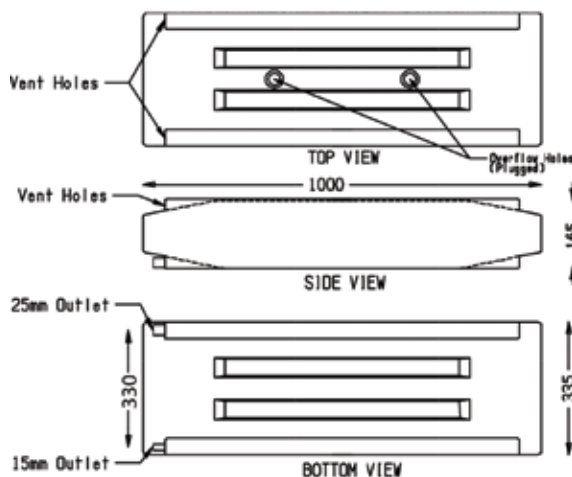

**800-01520**  
**ROUND ENDED TANK**  
61L round ended tank



**Specifications**

Dimensions: 900mm x 490mm x 165mm

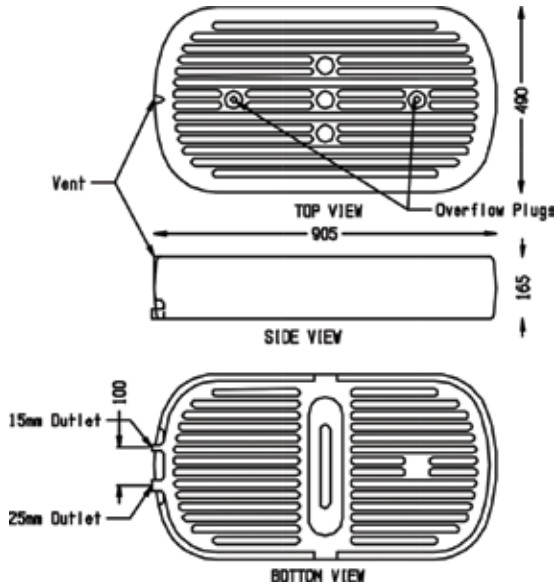

**800-01530**  
**MILLARD TANK**  
63L Millard tank



**Specifications**

Dimensions: 860mm x 525mm x 160mm

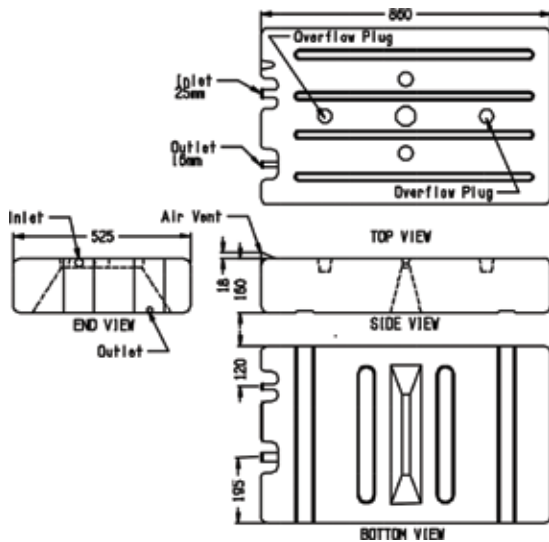

**WATER TANKS**

**800-01540**  
**84L STANDARD TANK**



**Specifications**

Dimensions: 864mm x 508mm x 216mm

**800-01567**  
**WATER TANK BUNGS FOR 65L AND 80L TANKS**



**800-01569**  
**WATER TANK BUNGS FOR 140L TANKS**



**COAST TANK**

**800-01574**  
**90L WATER TANK WITH TAP**

Has a 25mm barb.



**Specifications**

Dimensions: 1270L x 400W x 210H (mm)

**800-01576**  
**TOP CAP FOR JAYCO WATER TANK**



**800-01577**  
**SPARE TAP FOR 800-01574**



## HEAVY DUTY WATER TANKS

Heavy duty water tanks, robust construction with inbuilt mounting flange complete with fittings and threaded for tap facility.

**800-01580**  
**65L TANK**
**Specifications**

Dimensions: 810 x 190 x 615mm

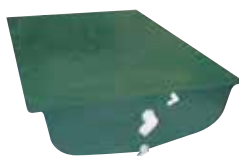
**800-01582**  
**83L TANK**
**Specifications**

Dimensions: 810 x 265 x 615mm

**800-01584**  
**140L TANK**
**Specifications**

Dimensions: 1500 x 200 x 690mm

**800-01590**  
**FIAMMA 70L**  
**WATER TANK**

The Fiamma 70L fresh water tank is made of non-toxic material and weighs 3.7kg. Comes with all necessary fittings for installation.



**Specifications**

Dimensions: 240D x 710L x 470Wmm

**800-01600**
**WATER TANK 43L MODULAR STANDARD**  
**860 X 260 X 220MM**

This new moulded modular caravan and RV water tank will change the way you use water tanks. This one tank can be configured in many ways to provide a single low cost solution.

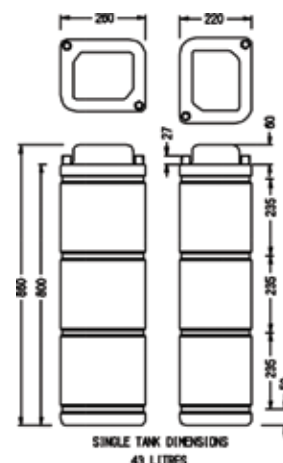
The BR Plastics tank is blow moulded from food contact approved High Molecular Weight High Density Polyethylene. This makes the tank a super tough performer. The tank is moulded with two integral 20mm (3/4 BSP) threaded closures that can accept a wide variety of standard fixtures and fittings. Using these standard fitting the tank can be networked together to provide almost limitless water storage options for your vehicle.

**800-01602**  
**WATER TANK 43L**  
**MODULAR PACK**  
**ONE 860 X 260**  
**X 220MM**

Pack One consists of:

- > 1 x 43L Tank
- > 2 x Elbows
- > 1 x 12mm Director
- > 1 x 25mm Director

**800-01604**  
**WATER TANK 43L**  
**MODULAR PACK**  
**TWO 860 X 260**  
**X 220MM**

Pack One consists of:

- > 1 x 43L Tank
- > 1 x Tee
- > 1 x Cap
- > 2 x 25mm directors





**800-01606**  
**WATER TANK GREY WATER 50L MODULAR 698 X 382 X 210MM**

The BR Plastics tank is blow moulded from food contact approved High Molecular Weight High Density Polyethylene. This makes the tank a super tough performer. The tank is moulded with two integral 40mm (1.5" BSP) threaded female closures that can accept a wide variety of standard fixtures and fittings. Using these standard fittings the tank can be networked together to provide many water storage options for your vehicle.



**800-01608**  
**WATER TANK 54L CARAVAN AND RV WATER TANK 755 X 355 X 220MM**

The tank is moulded with three integral 20mm (3/4 BSP) threaded closers that can accept a wide variety of standard fixtures and fittings.



**TAP FITTINGS**

**800-01327**  
**3/4" BSP SPRINKLER ADAPTOR**



**800-01241**  
**ADAPTOR KIT FOR MARINE AND OUTDOOR WATER HOSE**

Allows you to attach the hose to any garden tap. Each kit contains a tap adaptor and two snap-on hose fittings.



**800-01991**  
**HOLMAN ADAPTER SET**  
3 piece brass adapter set.



**800-01992**  
**NETA 1 1/6" 12MM BRASS CLICK ON SPRAY ADAPTOR**

Screws into sprays or pumps and clicks into hose connections.



**JOHN GUEST PLUMBING FITTINGS**

**800-02000**  
**JG FEMALE PLASTIC CONNECTOR FOR 12MM X 3/8 FBSP**



**800-02001**  
**JG FEMALE PLASTIC CONNECTOR FOR 12MM X 3/8" FBSP**

Has a shallow (approx. 7mm deep) thread.



**800-02002**  
**JG FEMALE PLASTIC CONNECTOR FOR 12MM X 1/2 FBSP**



**800-02004**  
**JG 1/2 BARB FOR TUBE FITTING 15MM X 1/2"**



**800-02006**  
**JG STRAIGHT 12MM X 1/2 BSPT MALE ADAPTER**



## 7

## PLUMBING FITTINGS

**800-02008**  
**JG PLASTIC 12MM TEE**  
**CONNECTOR**



**800-02010**  
**JG PLASTIC 12MM ELBOW**  
**CONNECTOR**



**800-02012**  
**JG PLASTIC 12MM**  
**STRAIGHT CONNECTOR**



**800-02014**  
**JG PLASTIC 12MM X 1/2**  
**BSP STRAIGHT MALE STEM**  
**ADAPTER**



**800-02016**  
**JG PLASTIC**  
**12MM X 10MM JOINER**



**800-02018**  
**JG PLASTIC STEM ELBOW**  
**12MM CONNECTOR**



**800-02019**  
**JG BRASS STRAIGHT**  
**12MM X 1/2" NPT**



**800-02023**  
**JG 12MM TUBE INSERT**  
 Bag of 100



**800-02025**  
**JG 12MM LOCKING CLIP**  
 Bag of 100



**800-02026**  
**JG 1/2" BRASS MALE ADAPTER**  
**WITH 12MM PLASTIC ELBOW**



**800-02028**  
**JG 12MM PLASTIC SWIVEL**  
**ELBOW MALE 1/2" BSPT**



**800-02030**  
**JG 12MM EQUAL DIVIDER**



**800-02032**  
**JG 12MM SINGLE CHECK**  
**VALVE**



**800-02034**  
**JG 12MM BULKHEAD ADAPTER**



**800-02036**  
**JG 12MM SHUT-OFF VALVE**  
**PLASTIC**



**800-02038**  
**JG 12MM 3/8" STRAIGHT**  
**ADAPTER MALE PLASTIC**



**800-02040**  
**JG 12MM SERIES 08 RED**  
**PLUG**



**800-02042**  
**JG 12MM 1/2" TUBE**  
**TO HOSE BRASS**

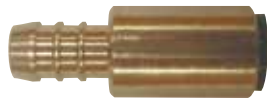

**800-02122**  
**JG BLACK 12MM X 10M ROLL**  
**OF TUBING**  
 UV stabilised, sold per 10m roll.



**800-02048**  
**JG TUBE TO HOSE CONNECTOR**  
**(12MM X 10MM)**



**800-02124**  
**JG RED 12MM X 10M ROLL**  
**OF TUBING**  
 No uv protection, sold per 10m roll.



**800-02098**  
**JG TUBE CUTTER**  
 (sold separately)



**800-02150**  
**PINK WATER SEAL**  
**TAPE 12MM X 10M**  
**ROLL**

- > Resistant to almost all types of acids, bases, solvents, chemicals etc., (with the exception of fluorine, some fluoride chemicals and melted alkali metals).
- > Non-flammable (ASTM D-635 D-470). Non-ageing. High tensile strength even at low temperatures. Break-down resistant, especially, in connection with bending and vibration
- > Suitable for Natural Gas and LPG (Propane and Butane)



**800-02100**  
**JG BLUE 12MM X 100M ROLL**  
**OF TUBING**  
 UV resistant, sold per 100m roll.

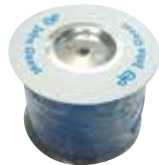

**800-02101**  
**JG COLLET LOCKING TOOL**  
 A spacing tool used to help create space for, or remove, a locking clip.



**800-02102**  
**JG BLACK 12MM X 100M ROLL OF**  
**TUBING**  
 UV stabilised, sold per 100m roll.



**800-02104**  
**JG RED 12MM X 100M ROLL**  
**OF TUBING**  
 No uv protection; sold per 100m roll.



**800-02120**  
**JG BLUE 12MM X 10M ROLL**  
**OF TUBING**  
 UV resistant, sold per 10m roll.



## JOHN GUEST WATERMARK FITTINGS

The John Guest Speedfit RV Range has been specifically designed to meet Australian Standards and to be WaterMark compliant. The benefits of this range is its increased maximum working temperature and pressure. JG Speedfit tube fittings are warranted to achieve 80°C at 1000 kPa.

Push-fit plastic fitting for the connection of plastic and copper pipe. Designed, manufactured and assembled in the UK by John Guest Speedfit. Simply push the fitting fully onto the pipe and twist the plastic nut clockwise to lock in place. Should the need arise to demount the connection unlock the nut and push the collet towards the body of the fitting and pull the pipe to release. The fitting ensures an easier working environment in confined places and removes the need for hot works on site. Installation can be reduced by around 40% against traditional fixing methods.

**800-02200**

**JG WATERMARK EQUAL  
STRAIGHT CONNECTOR  
12MM PEMO412W**

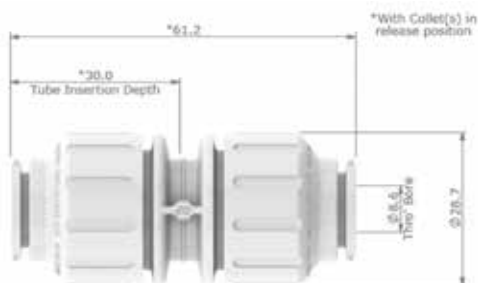

**800-02202**

**JG WATERMARK EQUAL  
ELBOW 12MM PEMO312W**

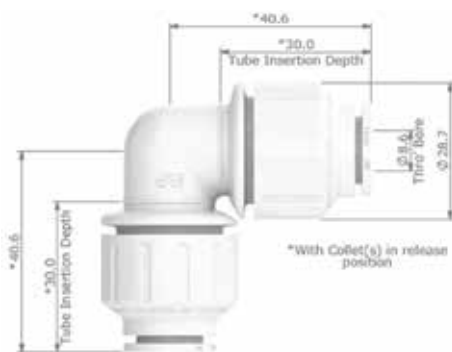

**800-02204**

**JG WATERMARK EQUAL  
TEE 12MM PEMO212W**

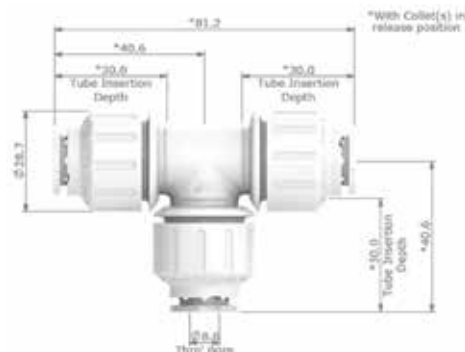

**800-02206**

**JG WATERMARK STEM  
ELBOW 12MM PEM22121W**

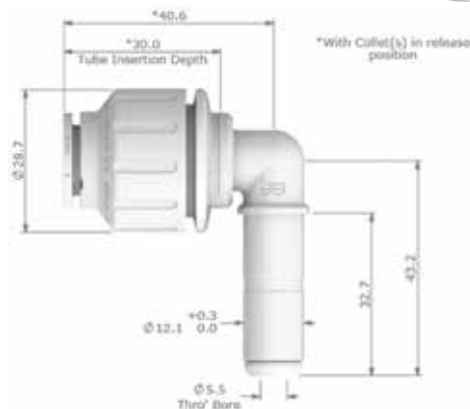

**800-02208**

**JG WATERMARK STEM TEE  
12MM PEM531212W**

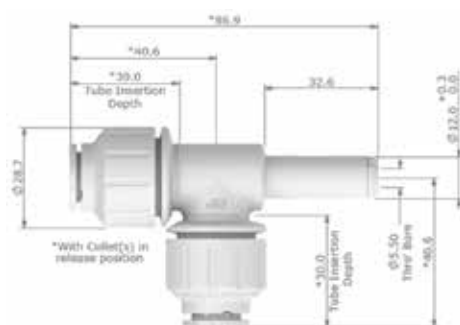



**800-02210**  
**JG WATERMARK STEM**  
**REDUCER 12MM PEM061612W**

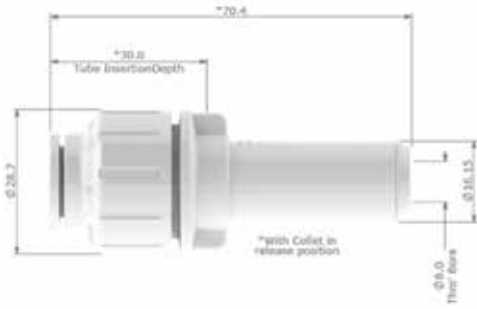

**800-02216**  
**JG WATERMARK END CAP**  
**12MM PSE4612W**

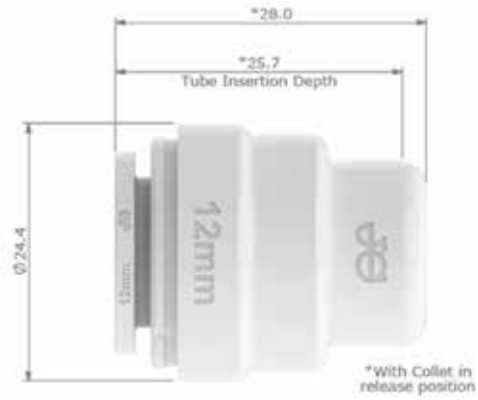

**800-02212**  
**JG WATERMARK STRAIGHT**  
**TAP CONNECTOR 12MM**  
**PEMSTC1214 1/2 BSP**

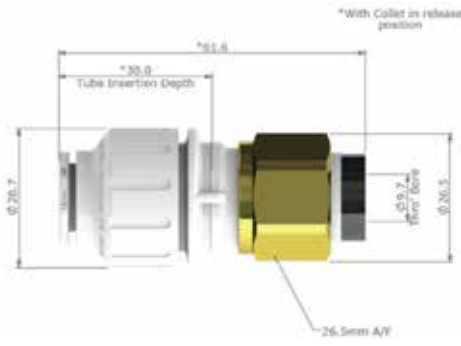

**800-02218**  
**JG WATERMARK MALE**  
**ADAPTOR 12MM NC2771**  
**1/2 BSPT**

Ideal for use with Suburban HWS

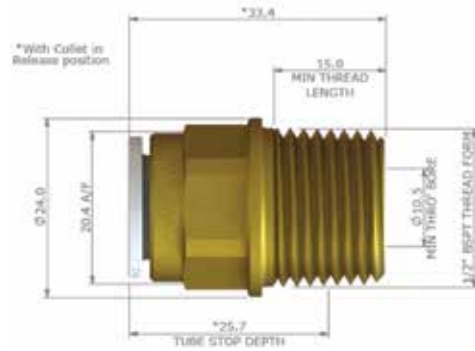

**800-02214**  
**JG WATERMARK BENT**  
**TAP CONNECTOR 12MM**  
**PEMBTC1214 1/2 BSP**



**800-02220**  
**JG WATERMARK FEMALE**  
**ADAPTOR 12MM MW451213**  
**3/8 BSP**

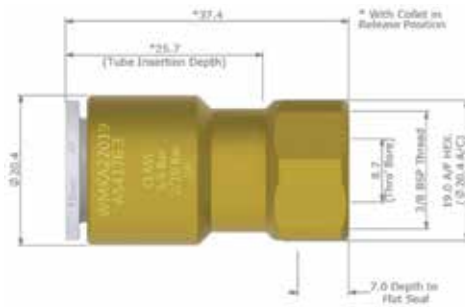

**800-02223**  
**JG WATERMARK TUBE**  
**INSERT 12MM TSM12**  
 Bag of 50



**800-02224**  
**JG WATERMARK BPEX**  
**TUBE 12MM X 50MM**  
**12BPEX-50C**



**800-02227**  
**JG WATERMARK**  
**COLLECT CLIP BLUE**  
**12MM CM1812B**  
 Bag of 100



**800-02229**  
**JG WATERMARK**  
**COLLECT CLIP RED**  
**12MM CM1812R**  
 Bag of 100



### PLASTIC PLUMBING FITTINGS

**800-02300**  
**PLASTIC BARBED**  
**ELBOW 13MM**



**800-02302**  
**PLASTIC BARBED**  
**ELBOW 19MM**



**800-02304**  
**PLASTIC BARBED**  
**ELBOW 25MM**



**800-02306**  
**PLASTIC BARBED**  
**JOINER 13MM**



**800-02308**  
**PLASTIC BARBED**  
**JOINER 19MM**



**800-02310**  
**PLASTIC BARBED**  
**JOINER 25MM**



**800-02312**  
**PLASTIC BARBED**  
**TEE 13MM**



**800-02314**  
**PLASTIC BARBED**  
**TEE 19MM**



**800-02316**  
**PLASTIC BARBED**  
**TEE 25MM**



**800-02318**  
**PLASTIC BARBED**  
**END PLUG 13MM**



**800-02320**  
**PLASTIC BARBED**  
**END PLUG 19MM**



800-02322  
PLASTIC BARBED END  
PLUG 25MM



800-02324  
PLASTIC BARBED  
REDUCING JOINER  
19MM X 13MM



800-02326  
PLASTIC BARBED  
REDUCING JOINER  
25MM X 13MM



800-02328  
PLASTIC BARBED  
REDUCING JOINER  
25MM X 19MM



800-02330  
19MM BARBED X 13MM  
BRANCH TEE



800-02332  
25MM BARBED X 13MM  
BRANCH TEE



800-02334  
25MM BARBED X 19MM  
BRANCH TEE



800-02336  
13MM BARBED X 19MM  
BRANCH TEE



800-02338  
19MM BARBED X 25MM  
BRANCH TEE



800-02340  
13MM BARBED X 1/2" BSP  
FEMALE THREADED ELBOW



800-02342  
19MM BARBED X 1/2" BSP  
FEMALE THREADED ELBOW



800-02344  
25MM BARBED X 1/2" BSP  
FEMALE THREADED ELBOW



800-02346  
13MM BARBED X 1/2" BSP  
FEMALE THREADED TEE



800-02348  
19MM BARBED X 1/2" BSP  
FEMALE THREADED TEE



800-02350  
25MM BARBED X 1/2" BSP  
FEMALE THREADED TEE



800-02352  
13MM BARBED X 1/2" BSP  
MALE THREADED TEE



800-02354  
19MM BARBED X 1/2" BSP  
MALE THREADED TEE



# 7

## PLUMBING FITTINGS

**800-02356**  
19MM BARBED X 3/4" BSP  
MALE THREADED TEE



**800-02372**  
19MM BARBED X 1/2" BSP  
MALE THREADED CORNER  
ELBOW



**800-02358**  
25MM BARBED X 1/2"  
BSP MALE THREADED  
TEE



**800-02374**  
19MM BARBED X 1/2" BSP  
FEMALE THREADED CORNER  
ELBOW



**800-02360**  
25MM BARBED X 3/4" BSP  
MALE THREADED TEE



**800-02376**  
25MM BARBED X 1/2" BSP  
MALE THREADED CORNER  
ELBOW



**800-02362**  
13MM BARBED X 1/2" BSP  
MALE THREADED ELBOW



**800-02378**  
19MM BARBED X 1/2" BSP  
MALE THREADED SIDE  
OUTLET TEE



**800-02364**  
19MM BARBED X 1/2" BSP  
MALE THREADED ELBOW



**800-02380**  
19MM BARBED X 1/2" BSP  
FEMALE THREADED SIDE  
OUTLET TEE



**800-02366**  
19MM BARBED X 3/4" BSP  
MALE THREADED ELBOW



**800-02382**  
3/4" BSP NUT X 13MM TAIL



**800-02368**  
25MM BARBED X 1/2" BSP  
MALE THREADED ELBOW



**800-02384**  
3/4" BSP NUT X 19MM TAIL



**800-02370**  
25MM BARBED X 3/4" BSP  
MALE THREADED ELBOW



**800-02385**  
NUT AND TAIL HANSEN (40MM)  
- 1.5" BSPT X 40MM TAIL





**800-02386**  
**1" BSP NUT X 13MM TAIL**



**800-02388**  
**1" BSP NUT X 19MM TAIL**



**800-02390**  
**1" BSP NUT X 25MM TAIL**



**800-02392**  
**PLASTIC BARBED IN-LINE VALVE 25MM**



**800-91000N**  
**PIPELINE FEMALE CAMLOCK WITH HOSE TAIL (25MM)**  
Made from polypropylene with a 25mm thread.



**800-91002N**  
**PIPELINE FEMALE CAMLOCK WITH HOSE TAIL (32MM)**  
Made from polypropylene with a 32mm thread.



**800-91004N**  
**PIPELINE MALE CAMLOCK (25MM)**  
Made from polypropylene with a 25mm BSP thread.



**800-91006N**  
**PIPELINE MALE CAMLOCK (32MM)**  
Made from polypropylene with a 32mm BSP thread.



**800-91008N**  
**PIPELINE DUST CAP (25MM)**  
Made from polypropylene with a 25mm BSP thread.



**800-91010N**  
**PIPELINE DUST CAP (32MM)**  
Made from polypropylene with a 32mm BSP thread.



**800-91012N**  
**PIPELINE BALL VALVE (25MM)**  
Made from polypropylene, this spin weld ball valve has a 25mm thread.



**800-91014N**  
**PIPELINE BALL VALVE (32MM)**  
Made from polypropylene, this spin weld ball valve has a 32mm thread.



**800-91016N**  
**PIPELINE GREY HOSE - 25MM**  
Sold per metre.



**800-91018N**  
**PIPELINE GREY HOSE - 32MM**  
Sold per metre.



**800-91020N**  
**PIPELINE WASTE KIT WITH HOSE (25MM)**  
Kit consists of: x1 800-91012N, x1 800-91000N, x1 800-91004N, x1 800-91008N and x3 800-91016N



**800-91022N**  
**PIPELINE WASTE KIT WITH HOSE (32MM)**  
Kit consists of: x1 800-91014N, x1 800-91002N, x1 800-91006N, x1 800-91010N and x3 800-91018N



## FUEL SAFE ALL PLASTIC CANS

These fuel safe cans are made from high strength polyethylene for the safe transportation of fuel and other flammable liquids. Features an anti-glug pourer.

### 800-02400 FUEL SAFE PLASTIC 5L FUEL CAN



### 800-02410 FUEL SAFE PLASTIC 10L FUEL CAN



### 800-02420 FUEL SAFE PLASTIC 20L FUEL CAN



## ACCUMULATOR TANKS

### 800-03000 SHURFLO ACCUMULATOR TANK



### 800-03010 FIAMMA A20 ACCUMULATOR TANK



### 800-91096N ROLL TANK HOSE KIT (25MM)

Kit consists of: x2 800-91000N and x1 800-91016N



### 800-91098N ROLL TANK HARDWARE KIT (25MM)

Kit consists of: x1 800-91024N, x1 800-91026N, x1 800-91028N, x1 800-91004N, x1 800-91008N and x1 800-91030N



## JRV TANK MONITOR

### 800-03100 Features

Easy to install, has gauges for 2 fresh water tanks, 1 grey water tank, Battery level indicator and has pump switch



#### Specifications

Dimensions: 119W x 98H x 13D (mm)

### 800-03102 Features

Easy to install, has a gauge for 1 fresh water tank, Battery level indicator and has pump switch



#### Specifications

Dimensions: 119W x 98H x 13D (mm)

### 800-03104 Features

Easy to install, has gauges for 2 fresh water tanks, Battery level indicator and has pump switch



#### Specifications

Dimensions: 119W x 98H x 13D (mm)

### 800-03196 WATER SENSOR TANK HARNESS

### 800-03198 JRV TANK WELL NUT ONLY FOR MONITOR

**800-04030**

**TASTE PURE (WATER FRESHENER)**

Eliminate algae and slime buildup from drinking water tanks. Just 28 grams helps remove bad smells and taste from 75L of water (473ml Bottle)



**800-04110**

**NATURAL WATER CLEANOXIDE GEL**

Unlike most conventional Odour treatments that merely mask bad smells our CleanOxide® Gel actually has the ability to kill the source of the problem. The Chlorine Dioxide that is released from the Gel works by destroying part of the odour molecule, stripping it of its odour potential. It is the oxygen ions that are doing the work, killing the airborne bacteria, mould or viruses and safely eliminating odour.



- > Slow regulated release of chlorine dioxide vapour at undetectable and safe levels.
- > Simple mixing instructions
- > 1 packet treats up to 25m<sup>2</sup> (floor area).

**800-04040**

**GREY WATER DEODORISER**

Deodorize black and grey water tanks with these compact tablets. One tablet treats up to 150L. (Pack of 6)



**800-04042**

**CAMCO TST GREY WATER ODOR CONTROL - 32 OZ 946 ML**

Remove grease buildup in your grey water tank, sink and shower drain lines with this concentrated treatment. Only 100ml per 140L eliminates foul odors, leaving a fresh lemon scent.



**800-04120**

**TANK CLEANSE PRO**

Tank Cleanse Pro is the ultimate water tank cleaner, destainer and sanitiser.

Ideal for Caravan, Motorhome and Boat water tanks, Tank Cleanse Pro's concentrated formula ensures that freshwater systems are free from water tainting.



Over time, stagnant water in your RV's water tank allows for the build-up of algae, mould and other harmful bacteria. Cleanse your freshwater tank for better tasting drinking and cooking water with Tank Cleanse Pro.

Tank Cleanse Pro's concentrated formula treats up to 200L of water.

**800-04100**

**NATURAL WATER CHLORINE DIOXIDE TABLETS 8 X 4 GRAMS**

Water tanks in caravans and campers need to be treated regularly to ensure there is no harmful build-up of micro-organisms and biofilm. The fact that caravans are often not used for prolonged periods of time makes it even more crucial to keep the water safe for cooking and consumption.



Organic material in water tanks can be harmful to your health and negatively affects the taste and odour of water. The build-up of biofilm in pipes can also cause problems in the flow-rate and longevity of your system. CleanOxide®, which is Chlorine Dioxide, is the most effective product on the market to clean water tanks and ensure the water is safe for consumption.

- > Effective over a broad pH range (4 to 10)
- > Controls bacteria, fungi, viruses, biofilm and algae.
- > Neutralises unpleasant taste and odours from tank water.
- > Safer than Chlorine. CleanOxide® does not react with ammonia and does not produce toxic compounds in contact with organic materials present in water.
- > Effective at lower dose rates than chlorine or bromine.
- > Non-corrosive at the recommended dose rates
- > Bio-degrades in sunlight, so no harmful effect on the environment when flushing your tank.
- > Micro-organisms do not develop resistance to CleanOxide®.
- > Approved in Australia for the treatment of drinking water since 2005.
- > Each 4 gram tablet treats 100 to 400 litres of water.

**SINKS**

**800-04900**

**ARGENT SINK MK3 (LEFT HAND)**

This Argent sink has a left handed drain and comes with a smoked black glass lid.



**Specifications**

- Overall Dimensions:** 152H x 630W x 470D (mm)
- Worktop Cut-Out Dimensions:** 605W x 415D (mm)
- Inside Bowl Dimensions:** 100H x 290W x 368D (mm)
- Sink Capacity:** 9.6L
- Net Weight:** 5.5kg

## 800-04910 KITCHEN CENTRE MK3

A complete kitchen sink set, including plastic wash bowl, chopping board, draining board and draining rack. All accessories fit inside the stainless steel sink when not being used, which makes the Kitchen Centre a beautiful space saver. Comes with a smoked black glass lid.



### Specifications

Overall Dimensions: 153H x 360W x 470D (mm)  
Worktop Cut-Out Dimensions: 335W x 430D (mm)  
Inside Bowl Dimensions: 99H x 290W x 368D (mm)  
Sink Capacity: 11L  
Net Weight: 3.6kg

## 800-04980 SMEV BASIN WITH MIXER TAP

A flush mount, stainless steel basin with a glass lid. It comes with a plug and waste kit.



### Specifications

Dimensions: 145H x 420W x 440D (mm)



## 800-04982 SMEV SINK WITH DRAINER

A flush mount, stainless steel basin that comes with a plug and waste kit.



### Specifications

Dimensions: 125H x 590W x 370D (mm)

## 800-04984 SMEV SINK WITH DRAINER

A flush mount, stainless steel basin that comes with a plug and waste kit.



### Specifications

Dimensions: 145H x 650W x 380D (mm)

## 800-04986 SMEV SINK (SQUARE)

A top fixing stainless steel sink with an inox finish. Comes with a plug and waste kit.



### Specifications

Dimensions: 370W x 370D x 125H (mm)

## 800-04988 SMEV SINK (RECTANGULAR)

A flush mount stainless steel sink with an inox finish. Comes with a plug and waste kit.



### Specifications

Dimensions: 280W x 380D x 145H (mm)



## THETFORD SINKS

## 800-90004N THETFORD SINK - LEFT HAND DRAIN

A top mount stainless steel sink with left hand drain section. It also features a smoked glass lid which allows you to maximize your work area whilst it is closed.



### Specifications

Dimensions: 630W x 475D x 160D (mm)

## 800-90006N THETFORD SINK - RIGHT HAND DRAIN

A top mount stainless steel sink with right hand drain section. It also features a smoked glass lid which allows you to maximize your work area whilst it is closed.



### Specifications

Dimensions: 630W x 475D x 160H (mm)

## 800-90008N THETFORD BASIC LINE 340 SINK

A stainless steel sink with a black glass lid and water tap hole. It is easy to clean and comes with a siphon and bung (a plug), it weighs just 2.9kg.



### Specifications

External Dimensions: 140H x 400W x 445D (mm)  
Cut Out Dimensions: 387W x 429D (mm)  
Capacity: 7.5L



800-04957

**KITCHEN SINK 2011**

Stylish and modern stainless steel sink and drainer with rounded corners and round bowl, complete with fitting brackets.



**Specifications**

Length: 720mm  
Wide: 440mm  
Bowl Diameter: 365mm  
Bowl Depth: 160mm

800-04997

**SMEV SINK RUBBER SEAL**

Black rubber seal for SMEV sinks, sold in 3m lengths.



800-05112

**RUBBER SINK PLUG**

Red rubber sink plug 25mm with pull shackle.



800-90500N

**THETFORD BEZEL FOR SINKS (BLACK)**

A rubber bezel suited to 800-90000N and 800-90002N and is sold per metre. Suitable for use as a sealant around the edges of a sink (instead of using a silicone sealant).



**WASTE OUTLETS**

800-05150

**WASTE OUTLET 25MM STRAIGHT WHITE**



800-04992

**SMEV SINK PLUG**

A replacement plug to suit Smev sinks and has a 38mm diameter.



800-05152

**WASTE OUTLET 25MM STRAIGHT GREY**



800-04994

**SMEV PLUG AND WASTE KIT (STRAIGHT)**

Plug and waste kit to suit SMEV sink (25mm straight)



800-05160

**WASTE OUTLET 25MM 90° WHITE**



800-04996

**PLUG AND WASTE KIT TO SUIT SMEV SINK (25MM 90°)**



800-05162

**PLASTIC SILVER/GREY 25MM WASTE OUTLET, 90°**



800-90502N

**SPINFLO 19MM WASTE STRAIGHT**



800-90504N

**SPINFLO 19MM WASTE ANGLED**



800-90506N

**SPINFLO 19MM SINK WASTE PLUG ONLY**

## CERAMIC BATHROOM BASINS

Modern round designed ceramic sink basins with a smooth glazed finish. Featuring a Fireclay construction for increased strength and durability, perfect for mobile applications.

- > Heat Resistant up to 1515°C
- > Impact Resistant
- > Dirt & Stain Resistant
- > Easy Cleaning
- > Chemical Resistant
- > Hypoallergenic

**800-06350**  
**CERAMIC BATHROOM ROUND BASIN (320X320X145MM)**  
**- GLOSS WHITE**



**800-06351**  
**CERAMIC BATHROOM OVAL BASIN (405X330X145MM)**  
**- GLOSS WHITE**



**800-06360**  
**CERAMIC BATHROOM OVAL BASIN (405X330X145MM)**  
**- MATT BLACK**



**800-06361**  
**CERAMIC BATHROOM OVAL BASIN (405X330X145MM)**  
**- MATT BLACK**



**800-06370**  
**CHROME PUSH BUTTON WASTE T/S WHITE CERAMIC BASINS**



**800-06371**  
**MATT BLACK PUSH BUTTON WASTE T/S BLACK BASINS**



## EXTERNAL SHOWER BOX WATERMARKED

A lockable external shower unit with hot and cold mixer taps, perfect for cleaning up before entering your RV.

- > Can be mounted either vertically or horizontally with soap holder feature moulded into the body.
- > Hand Shower Holder can be fitted inside of the door to suit mounting orientation
- > Feature quarter turn ceramic disk valves so the fittings turn in the opposite direction remaining mirrored in the open position.
- > Watermarked Approved tap and fittings
- > Supplied with soft backing gasket

**Specifications**  
 Dimensions: 325W x 200H x 99D (mm)

**800-05900**  
**EXTERNAL SHOWER BOX WATERMARKED**  
**- BLACK**



**800-05902**  
**EXTERNAL SHOWER BOX WATERMARKED - WHITE**



**800-06000**  
**AUX EXTERNAL SHOWER UNIT - BLACK**

UV and impact resistant, it features an enclosed casing which prevents potential water leakage into the wall of your RV. Thanks to the large flange, it can easily be retrofitted into other external shower cutouts. It comes with a key to lock the lid when not in use and an adjustable water flow toggle lever.



**Specifications**  
 Water Flow: 9,5L/min max.  
 Cut-out Dimensions: 150H x 279W (mm)  
 Total Depth: 119 (mm)

**800-06002  
AUX EXTERNAL  
SHOWER UNIT - WHITE**

UV and impact resistant, it features an enclosed casing which prevents potential water leakage into the wall of your RV. Thanks to the large flange, it can easily be retrofitted into other external shower cut-outs. It comes with a key to lock the lid when not in use and an adjustable water flow toggle lever.



**Specifications**

Water Flow: 9.5L/min max.  
Cut-out Dimensions: 150H x 279W (mm)  
Total Depth: 119(mm)

**SHOWER HOSES**

**800-06028  
HAND HELD SHOWER KIT**

Includes hose, rose and bracket.



**800-06030  
EUTOPIA HAND HELD  
SHOWER KIT**

Includes the hose, rose and bracket



**800-06040  
CHROME SHOWER  
HEAD KIT**

Save water with this showerhead kit, thanks to a handy on/off switch that allows you to pause the water flow whilst you shampoo. This showerhead features four spray patterns from a gentle spray to hard rain. Each kit includes: a chrome showerhead, flexible shower hose (1.5m), washers, a wall mount and hardware.



**HOT AND COLD SHOWER MIXERS**

**800-06102  
EUTOPIA WHITE SHOWER  
MIXER 1/2" THREAD**



**800-06103  
EUTOPIA CHROME  
SHOWER MIXER  
1/2" THREAD**



**HAND PUMPS**

**800-06400  
TROJAN HAND PUMP - WHITE**

Has an efficient dual pumping action and its interior seals are made of polyurethane. Requires a 32mm hole.



**800-06404  
TROJAN EPD HAND PUMP - BLACK**

Has an efficient dual pumping action, its interior seals are made of polyurethane. Requires a 32mm hole



**800-06410  
BREHA HAND PUMP  
(PLASTIC SHAFT) WHITE**



**800-06414  
BREHA HAND PUMP  
(PLASTIC SHAFT) BLACK**



**800-06440**  
**LOWBOY HAND PUMP**  
 Lowboy Manual Hand Pump  
 White with Chrome Spout.



**800-06450**  
**COAST CHROME HAND PUMP**  
 Has a grey plastic shaft with chrome accents  
 and spout.

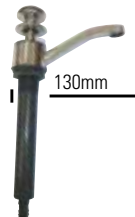

**800-06499**  
**LOWBOY HAND PUMP #131**  
**REPAIR KIT**



### BATHROOM MODULE

**800-06650**  
**VT90 MODULE LOWER**  
**BASIN SECTION ONLY**

**Specifications**  
 Dimensions: 820 x 670 x 160mm



**800-06655**  
**VT90 C400 TOILET**  
**SPACER**



**800-06660**  
**VT90 MODULE UPPER**  
**VANITY SECTION ONLY**  
**WITH MIRROR DOORS**



**Specifications**  
 Dimensions: 560H x 670W x 130D (mm)

**800-06670**  
**ACRYLIC SOAP HOLDER**  
**- WHITE**

**Specifications**  
 Dimensions: 328H x 220W x 90D



### COAST WATERMARK CHROME BATHROOM FIXTURES

**800-06700**  
**CHROME FLICK**  
**MIXER WITH 160MM**  
**SPOUT**



**800-06710**  
**CHROME FLICK**  
**MIXER WITH 190MM**  
**SPOUT**



**800-06720**  
**CHROME SHOWER FLICK**  
**MIXER**



**800-06730**  
**CHROME SHOWER RAIL**  
 with Hose, Rose and Soap Dish





**800-06750**  
**HIGH RISE SINK MIXER (35MM)**

Has a 4 star water rating, consuming 7.5L per minute. Comes with a 5yr manufacturer's warranty on the cartridge only.



**800-06760**  
**COAST SHOWER MIXER (35MM)**

A wall mountable shower mixer, comes with a 5yr manufacturer's warranty (on the cartridge only).



**800-06770**  
**COAST HIGH RISE SINK MIXER WITH 13CM SPOUT**



**800-06772**  
**COAST WATERMARK RIGHT HAND TAP, FOLD DOWN FAUCET**

Right hand tap, fold down chrome faucet, conveniently folds down into the sink when not being used. Can be used for hot or cold water (red and blue buttons included).



**Specifications**

Height: 180mm (when fitted)  
 Height when folded: 70mm (when fitted)  
 Thread Size: 3/8 FBSP WaterMarked Certified

**800-06774**  
**COAST WATERMARK LEFT HAND TAP, FOLD DOWN FAUCET**

Left hand tap, fold down chrome faucet, conveniently folds down into the sink when not being used. Can be used for hot or cold water (red and blue buttons included).



**Specifications**

Height: 180mm (when fitted)  
 Height when folded: 70mm (when fitted)  
 Thread Size: 3/8 FBSP WaterMarked Certified

**800-06776**  
**COAST WATERMARK HOT AND COLD MIXER FAUCET WITH FOLD DOWN SPOUT**

Hot and cold mixer faucet chrome with folding/swivel spout.



**Specifications**

Height: 200mm (when fitted)  
 Height when folded: 70mm (when fitted)  
 Thread Size: 3/8 FBSP WaterMarked Certified

**800-06900**  
**TV15 1/2 MALE TEMPERING VALVE**



**Specifications**

Cold Water Supply Temperature: 5°C - 30°C  
 Hot Water Supply Temperature: 60°C - 90°C  
 Set Temperature: 50°C standard (must be commissioned onsite by installer)  
 Accuracy of Outlet Temperature: +/- 3°C (as per AS4032.2)  
 Maximum Working Pressure (Static): 1400Kpa  
 Maximum Working Pressure (Dynamic): 500Kpa  
 Minimum Flow Rate: 3.6L/min under outlet pressure 10Kpa

**800-06902**  
**JG 12MM TEMPERING VALVE**



**Specifications**

Cold Water Supply Temperature: 5°C - 25°C  
 Hot Water Supply Temperature: 65°C - 80°C  
 Set Temperature: 50°C standard  
 Accuracy of Outlet Temperature: +/- 3°C  
 Maximum Working Pressure (Static): 16 Bar (1600Kpa)  
 Maximum Working Pressure (Dynamic): 5 Bar (500Kpa)  
 Minimum Flow Rate: 5.0L/min